

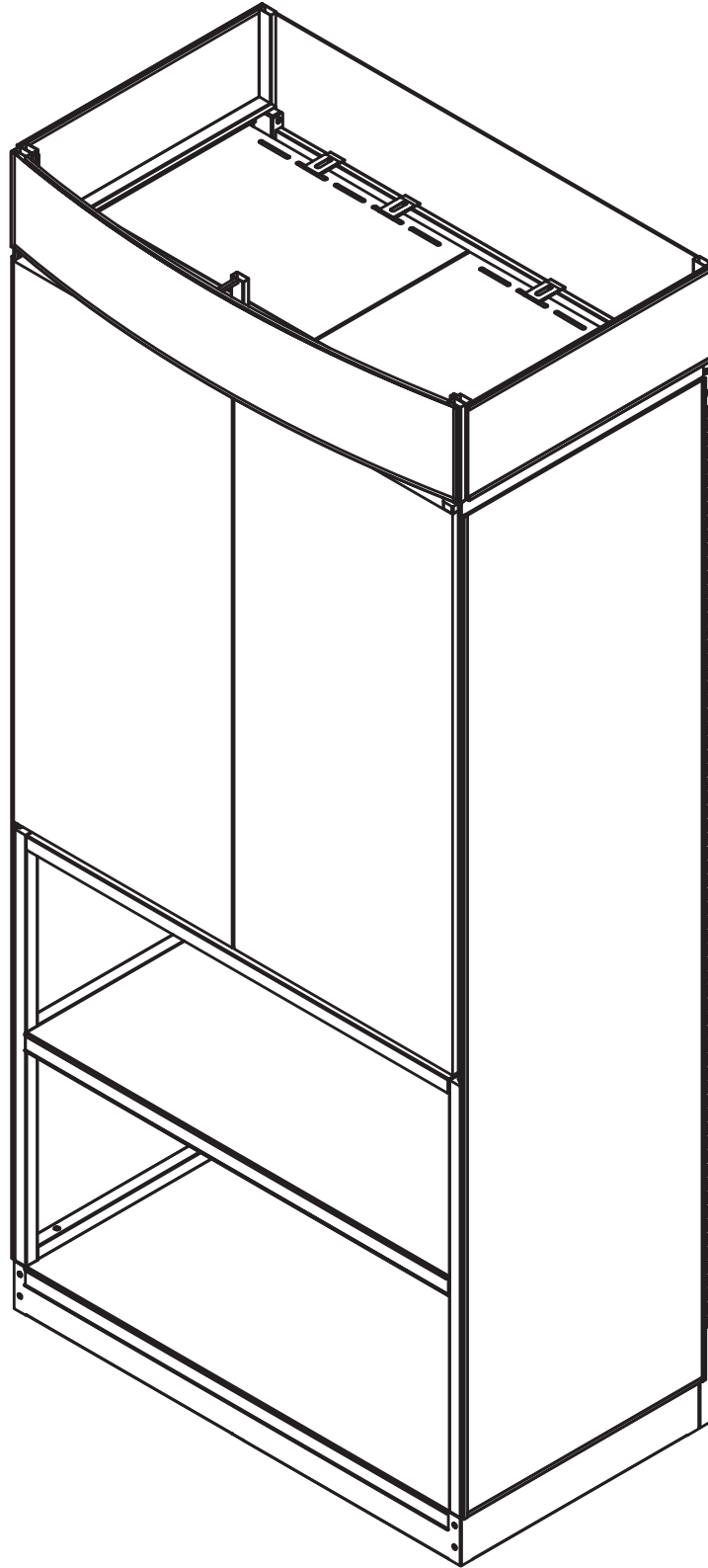







# Coca Cola Cooler End Cap - Assembly Instructions

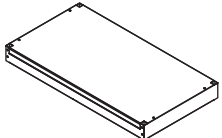
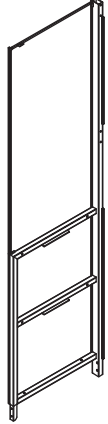
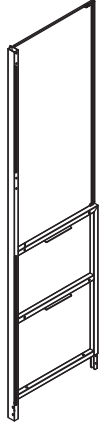
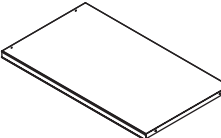
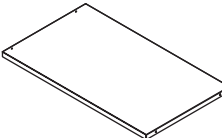
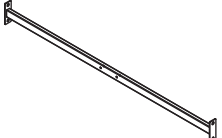
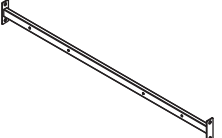
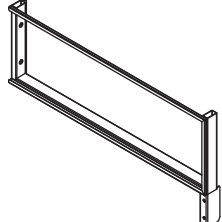
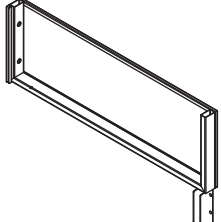
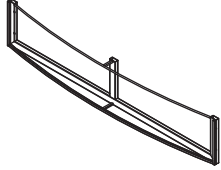
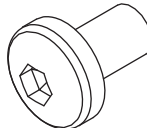
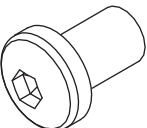
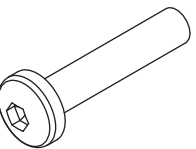
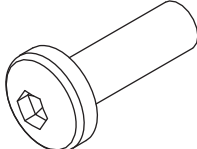
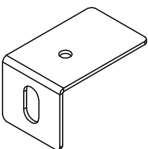
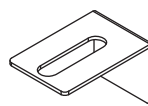
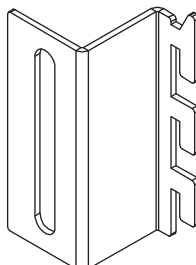
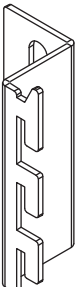
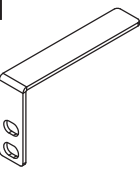
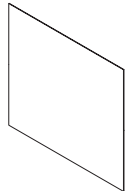
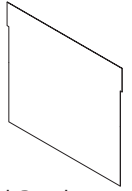
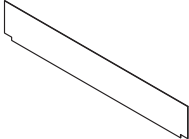

 Scan the QR code or visit [displaybuilds.com/instructions\\_17811](https://displaybuilds.com/instructions_17811) to view assembly video.

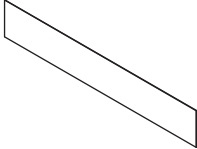
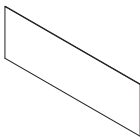

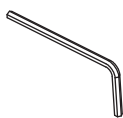
# Coca Cola Cooler End Cap - Assembly Instructions

<p><b>A</b></p>  <p>Base 1</p>	<p><b>B</b></p>  <p>Left Side Frame 1</p>	<p><b>C</b></p>  <p>Right Side Frame 1</p>	<p><b>D</b></p>  <p>Middle Shelf 1</p>	<p><b>E</b></p>  <p>Top Shelf 1</p>	<p><b>F</b></p>  <p>Middle Back Brace 1</p>
<p><b>G</b></p>  <p>Top Back Brace 1</p>	<p><b>H</b></p>  <p>Right Header Frame 1</p>	<p><b>I</b></p>  <p>Left Header Frame 1</p>	<p><b>J</b></p>  <p>Center Header Frame 1</p>	<p><b>K</b></p>  <p>M6x10 Hex Screw 28</p>	<p><b>L</b></p>  <p>M6x10 Flat Hex Screw 16</p>
<p><b>M</b></p>  <p>M6x35 Hex Screw 16</p>	<p><b>N</b></p>  <p>M6x20 Hex Screw 4</p>	<p><b>O</b></p>  <p>Cooler Top Bracket -1 4</p>	<p><b>P</b></p>  <p>Cooler Top Bracket -2 4</p>	<p><b>Q</b></p>  <p>Left Gondola Bracket 1</p>	<p><b>R</b></p>  <p>Right Gondola Bracket 1</p>
<p><b>S</b></p>  <p>Cooler Hook 1</p>	<p><b>T</b></p>  <p>Bottom Back Panel 1</p>	<p><b>U</b></p>  <p>Top Back Panel 1</p>	<p><b>V</b></p>  <p>Header Gap Panel 1</p>	<p><b>W</b></p>  <p>Side Panel POS 1</p>	<p><b>X</b></p>  <p>Center Header POS 2</p>
<p><b>Y</b></p>  <p>Side Header POS 2</p>	<p><b>Z</b></p>  <p>Channel Strips 2</p>	<p><b>AA</b></p>  <p>Allen Key 1</p>	<p>Scan the QR code or visit <a href="https://displaybuilds.com/instructions_17811">displaybuilds.com/instructions_17811</a> to view assembly video.</p> 		

# Coca Cola Cooler End Cap - Assembly Instructions

- 1** Insert (B) Left Side Frame into (A) Base. Secure by using two (M) M6x35 Hex Screws and tighten using (AA) Allen Key. Repeat to secure (C) Right Side Frame.

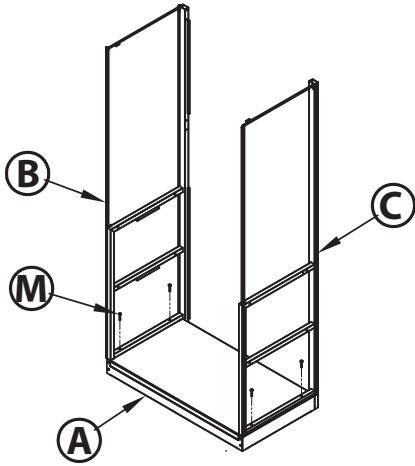

- 2** Continue to secure (B) Left Side Frame to base using two (K) M6x10 Hex Screws at the holes located on the front of the (A) Base using the (AA) Allen Key. Repeat to secure (C) Right Side Frame.

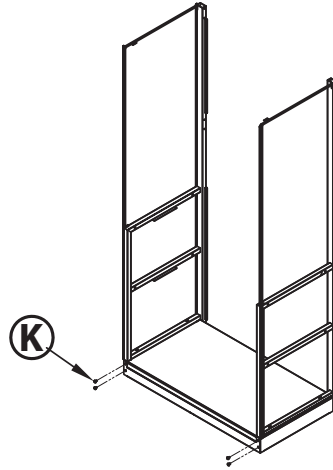

- 3** Continue to secure (B) Left Side Frame to base using two (M) M6x35 Hex Screws at the holes located on the back of the (A) Base using the (AA) Allen Key. Repeat to secure (C) Right Side Frame.

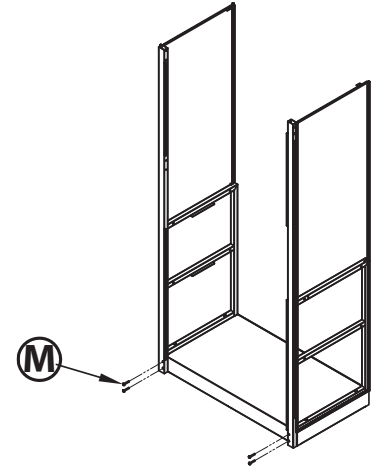

- 4** Install (D) Middle Shelf first by using four (M) M6x35 Hex Screws threading through the Side Frames and tightening with (AA) Allen Key. Repeat for (E) Top Shelf.

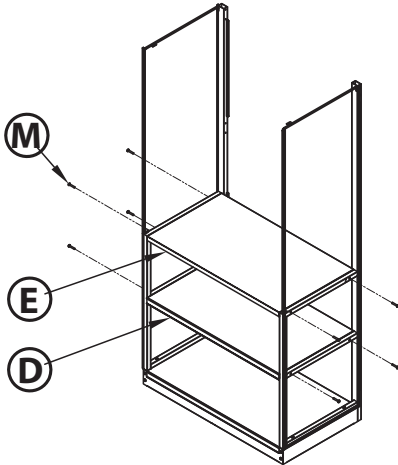

- 5** Secure (F) Middle Back Brace to Side Frames using four (K) M6x10 Hex Screws.

Repeat to secure (G) Top Back Brace.

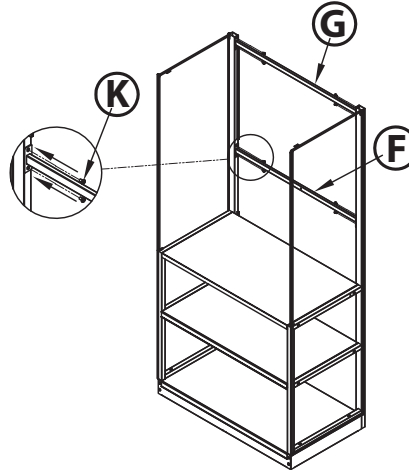

- 6** Insert (H) Right Header Frame into the tube located at the rear of (C) Right Side Frame. Tighten them with two (K) M6x10 Hex Screws.

Repeat above steps for (I) Left Header Frame.

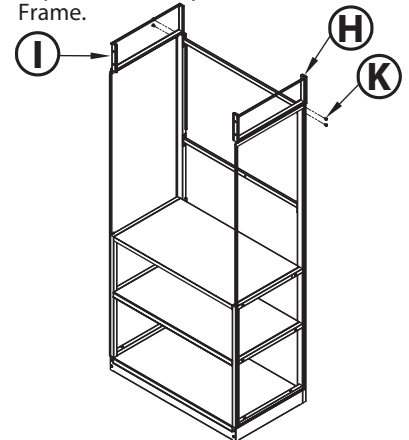

- 7** Secure (J) Center Header Frame to (I) Left and (H) Right Header Frames using four (N) M6x20 Hex Screws.

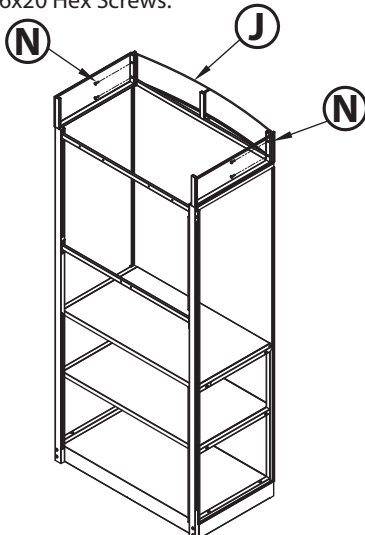

- 8** Align tab coming off of (B) Left Side Frame with the hole located on the bottom of the (I) Left Header Frame and secure using one (K) M6x10 Hex Screw. **Repeat steps** to secure (H) Right Header Frame to (C) Right Side Frame.

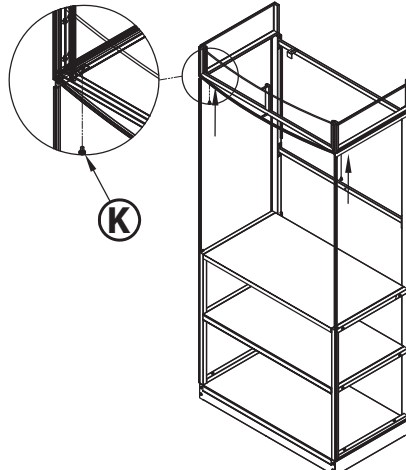

- 9** Slide (T) Bottom Back panel into bottom rear channels located at the back of Display.

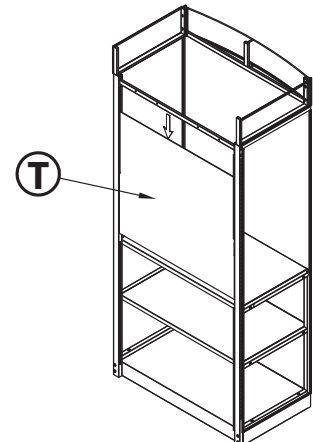

Scan the QR code or visit [displaybuilds.com/instructions\\_17811](https://displaybuilds.com/instructions_17811) to view assembly video.



# Coca Cola Cooler End Cap - Assembly Instructions

**10** Place the right cooler onto the top shelf. Insert (S) Cooler Base Bracket into base tube slot of cooler at the bottom rear of the cooler. Secure (S) Cooler Base Bracket with two (L) M6x10 Small Head Hex Screws. Repeat to secure left cooler.

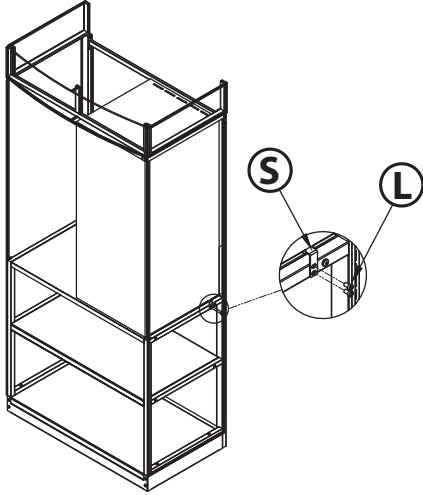

**11** Continue securing the coolers by using (O) Cooler Top Bracket - 1. Secure to (G) Top Back Brace using four (K) M6x10 Hex Screws.

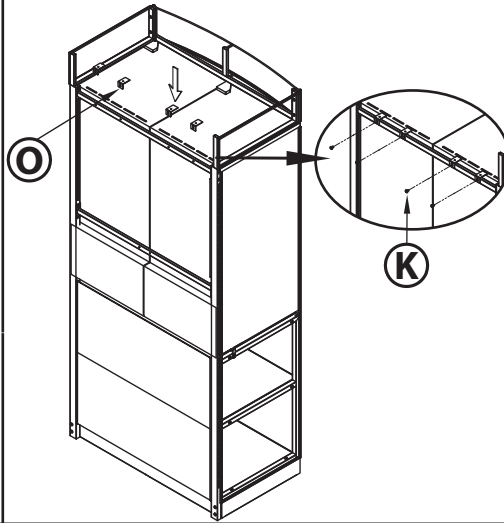

**12** Hook four (P) Cooler Top Bracket - 2 into the slots located at the top rear of the cooler. Secure (P) Cooler Top Bracket - 2 to (O) Cooler Top Bracket - 1 using four (K) M6x10 Hex Screws.

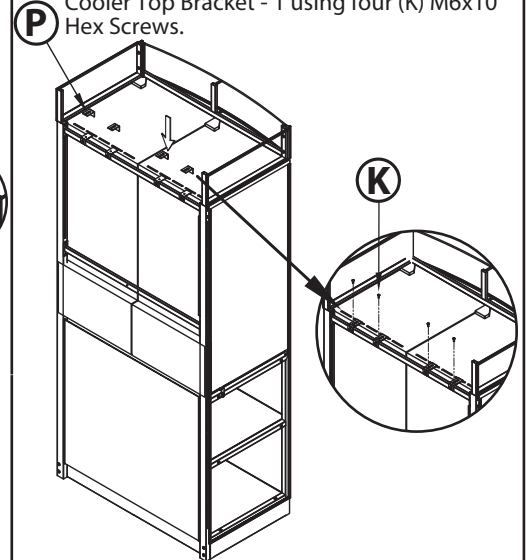

**13** Slide the (V) Header Gap Panel into the channels located behind the (J) Center Header Frame.

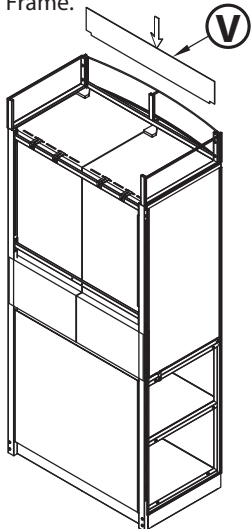

**14** Slide (U) Top Back Panel into top rear channels located at the back of the display.

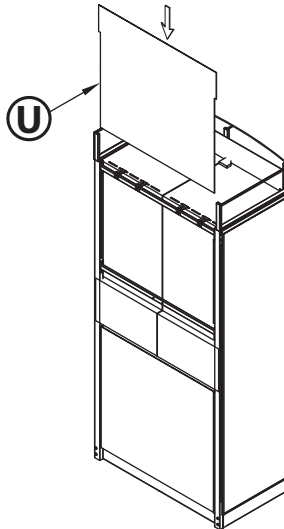

**15** Insert (X) Center Header POS into the Center Header Frame from top to bottom. Make sure bottom of the Center Header POS is in the base channel for proper installation.

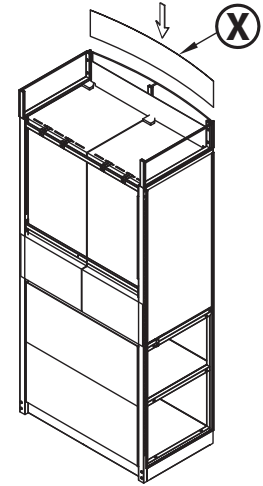

**16** Insert (Y) Side Header POS into (H) Right Header Frame and (I) Left Header Frame from front to back.

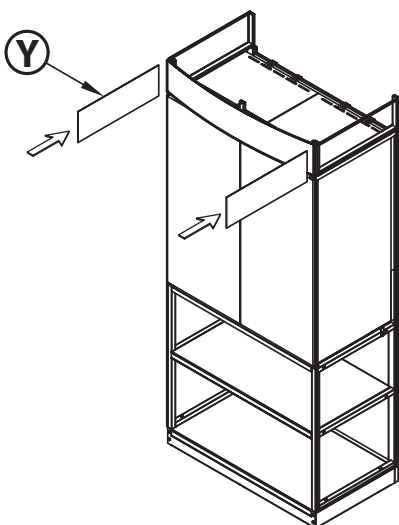

**17** Slide (W) Side POS into (B) Left Side Frame and (C) Right Side Frame.

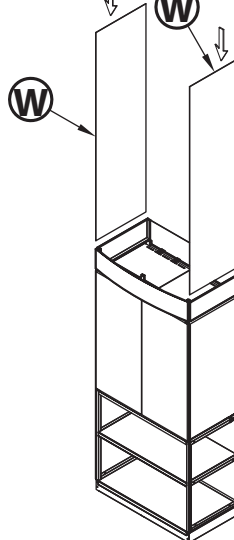

**18** Hook (Q) Left Gondola Hook and (R) Right Gondola Hook onto the Gondola at the height to line up with (F) Middle Back Brace. Secure using two (K) M6x10 Hex Screws.

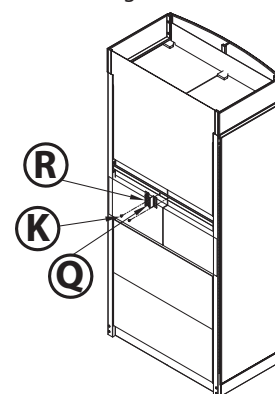

Scan the QR code or visit [displaybuilds.com/instructions\\_17811](https://displaybuilds.com/instructions_17811) to view assembly video.



## Coca Cola Cooler End Cap - Damage Claim/Parts Order Sheet

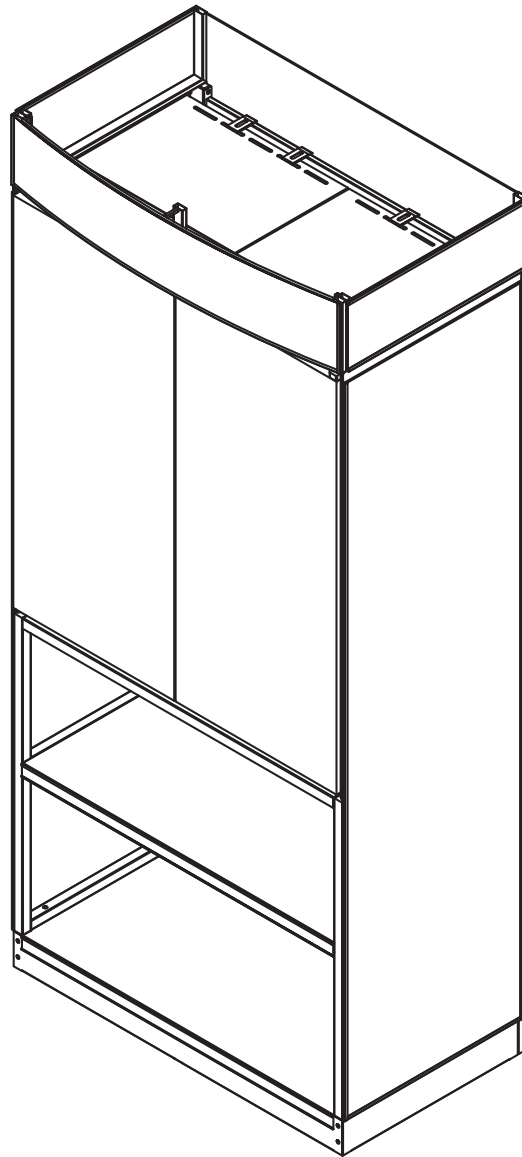

INSTALLATION MANUAL TO BE LEFT WITH STORE MANAGER AFTER INSTALLATION IS COMPLETED.



### MISSING PARTS / DAMAGE CLAIM INSTRUCTIONS

**1. DO NOT discard the box or original packaging.**

In the case of damaged goods caused by shipping, photo evidence will be required.

**2. Take photos of the box & markings.**

A photo of the markings (text) on the side of the box is required for all cases in which a replacement part is needed. This helps to identify the item number and ensures the correct parts are pulled.

**3. Take photos of damage (if applicable).**

A photo of the damaged part(s) is always required to file a claim and expediently process the replacement part. Please make sure you keep the box even if it is damaged.

**4. Send an email with the images requested.**

Email a description of the claim along with the images required above at [displaybuilds.com/contact](mailto:help@displaybuilds.com) or directly to [help@displaybuilds.com](mailto:help@displaybuilds.com). Call our toll-free number 1-866-308-8368 for further assistance.