

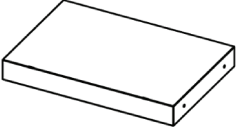

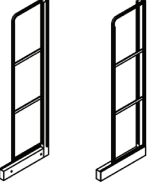



# Coca-Cola Dollar General 3x1 Floor Display - Assembly Instructions

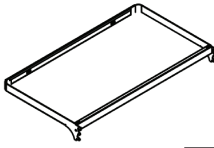
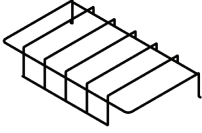
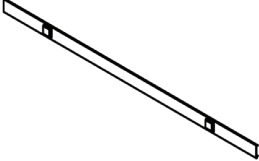

Scan the QR code or visit the web address directly to view the **assembly video**: [displaybuilds.com/instructions\\_17781](http://displaybuilds.com/instructions_17781)



<p><b>A</b></p>  <p><b>BASE</b></p> <p><b>1</b></p>	<p><b>B</b></p>  <p><b>LEFT AND RIGHT SIDE FRAME</b></p> <p><b>2</b></p>	<p><b>C</b></p>  <p><b>BRACE SUPPORTS</b></p> <p><b>2</b></p>	<p><b>D</b></p>  <p><b>ADJUSTABLE SHELVES</b></p> <p><b>2</b></p>	<p><b>E</b></p>  <p><b>SHELF DIVIDERS</b></p> <p><b>2</b></p>
<p><b>F</b></p>  <p><b>BASE CHANNEL SLIDE FRAME</b></p> <p><b>1</b></p>	<p><b>G</b></p>  <p><b>HEX BOLTS</b></p> <p><b>12</b></p>	<p><b>H</b></p>  <p><b>SIDE POS</b></p> <p><b>2</b></p>	<p><b>I</b></p>  <p><b>CHANNEL SLIDE POS</b></p> <p><b>3</b></p>	<p><b>J</b></p>  <p><b>BLACK BACK PANEL</b></p> <p><b>1</b></p>

**1** With the display laying down attach (B) Right and Left Side Frame to (A) Base using x4 (G) Hex Bolts and tighten with tool.

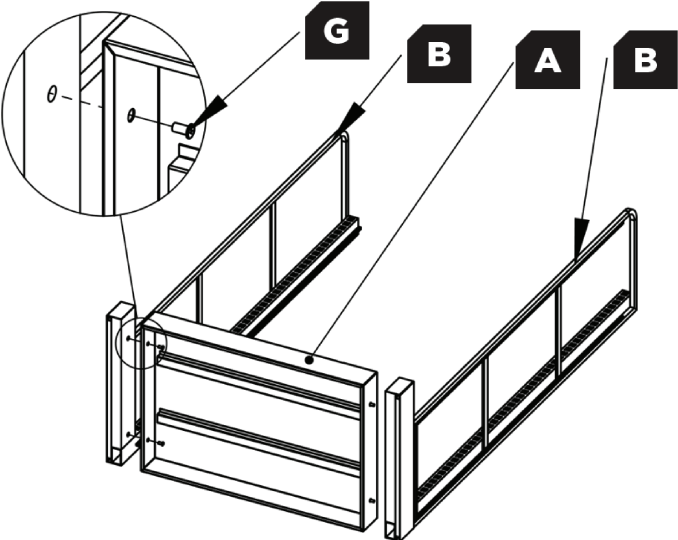

**2** Stand display upright and attach (C) Brace Supports to rear of the (B) Right and Left Side Frames using x8 (G) Hex Bolts and tighten with tool.

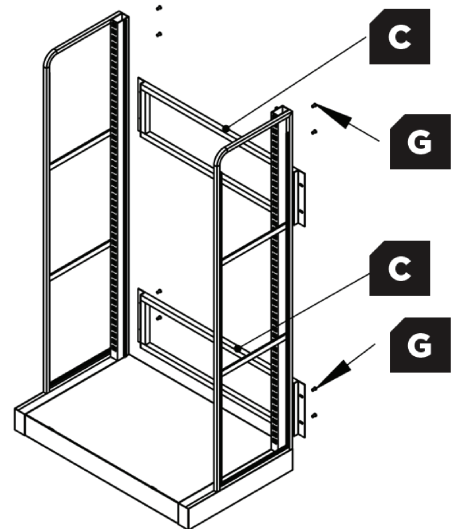

**3** Starting with the bottom shelf, hook (D) Adjustable Shelf onto the display at the required height. Then attach a (E) Shelf Divider by hooking it into the rear of the (D) Adjustable Shelf as shown. The (E) Shelf Divider should sit in the triangle holder at the front of (D) Adjustable Shelf.

Repeat these steps to install the top (D) Adjustable Shelf and (E) Shelf Divider.

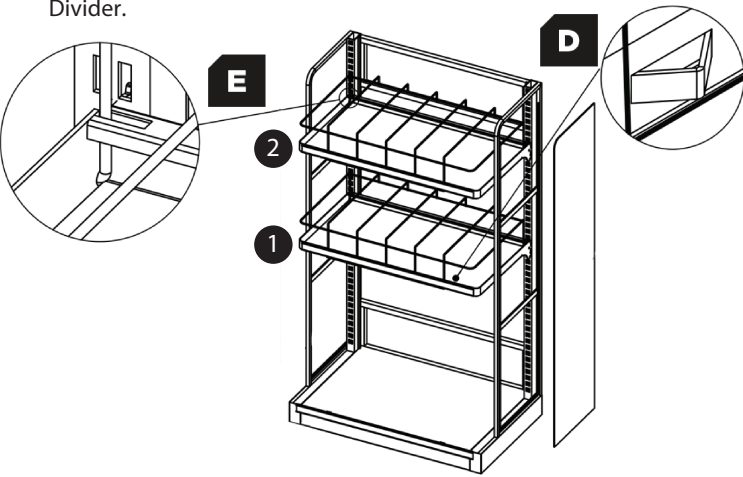

**4** Hook (F) Base Channel Slide onto the (A) Base. Slide (H) Side POS onto the sides of the display. If (I) Channel Slides are not already installed, slide them in place onto the (D) Adjustable Shelves and (F) Base Channel Slide. Finish the display by sliding the (J) Black Back Panel into place.

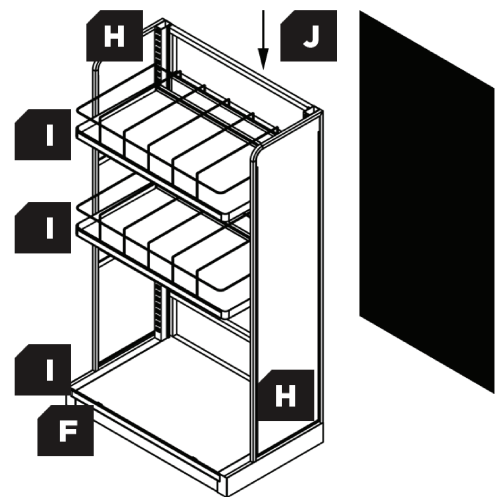

# Coca-Cola Dollar General 3x1 Floor Display - Assembly Instructions



Scan the QR code or visit the web address directly to view the **assembly video**: [displaybuilds.com/instructions\\_17781](https://displaybuilds.com/instructions_17781)



## MISSING PARTS / DAMAGE CLAIM INSTRUCTIONS

### 1. **DO NOT** discard the box or original packaging.

In the case of damaged goods caused by shipping, photo evidence will be required.

### 2. **Take photos of the box & markings.**

A photo of the markings (text) on the side of the box is required for all cases in which a replacement part is needed. This helps to identify the item number and ensures the correct parts are pulled.

### 3. **Take photos of damage (if applicable).**

A photo of the damaged part(s) is always required to file a claim and expediently process the replacement part. Please make sure you keep the box even if it is damaged.

### 4. **Send an email with the images requested.**

Email a description of the claim along with the images required above at [displaybuilds.com/contact](https://displaybuilds.com/contact) or directly to [help@displaybuilds.com](mailto:help@displaybuilds.com). Call our toll-free number 1-866-308-8368 for further assistance.