

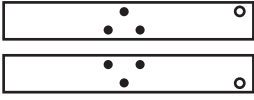

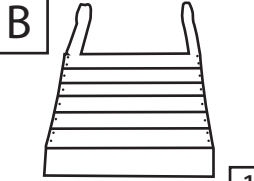

# Pyramid Brewing Co. Adirondack Chair - Assembly Instructions

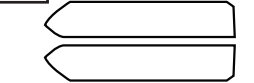
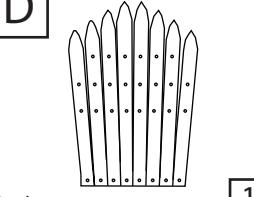

Scan the QR code or visit the web address directly to view the **assembly video**: [displaybuilds.com/instructions\\_17783](https://displaybuilds.com/instructions_17783)

<b>A</b>		2
<b>B</b>		1
<b>C</b>		2
<b>D</b>		1
<b>E</b>		10
<b>F</b>		8
<b>G</b>		2
<b>H</b>		2
<b>I</b>		1

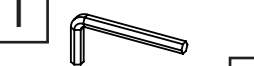
**BEFORE YOU BEGIN:**

Read through instructions from beginning to end before starting to assemble unit. Identify all parts and hardware. If anything is missing or damaged, refer to instructions on Page 2.

When laying out finished parts, place them on a clean, dry, and soft surface to prevent scratching.

**CAUTION:** Always have two people assemble this unit.

**ADDITIONAL TOOLS REQUIRED:** Phillips Head Screwdriver

**NOTE:** Install all screws and bolts hand tight. Tighten all only when fully assembled.

**2** Attach (C) Armrests to the (A) Legs with x2 (E) Bolts and x2 (F) Nuts and hand tighten.

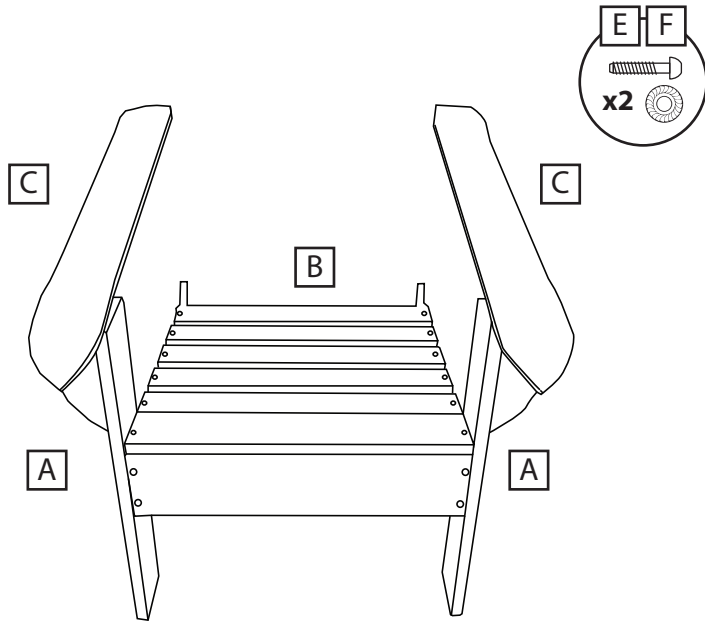

**1** Attach (A) Legs to (B) Seat Bottom using x6 (E) Bolts and (F) Nuts and hand tighten.

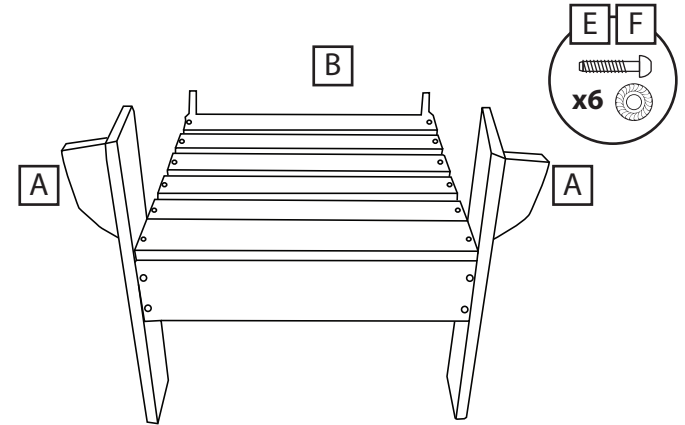

**3** Attach the (C) Armrests to the (D) Backrest with x2 (E) Bolts and x2 (G) Nuts. Then attach (D) Backrest to the (B) Seat Bottom with x2 (H) Screws.

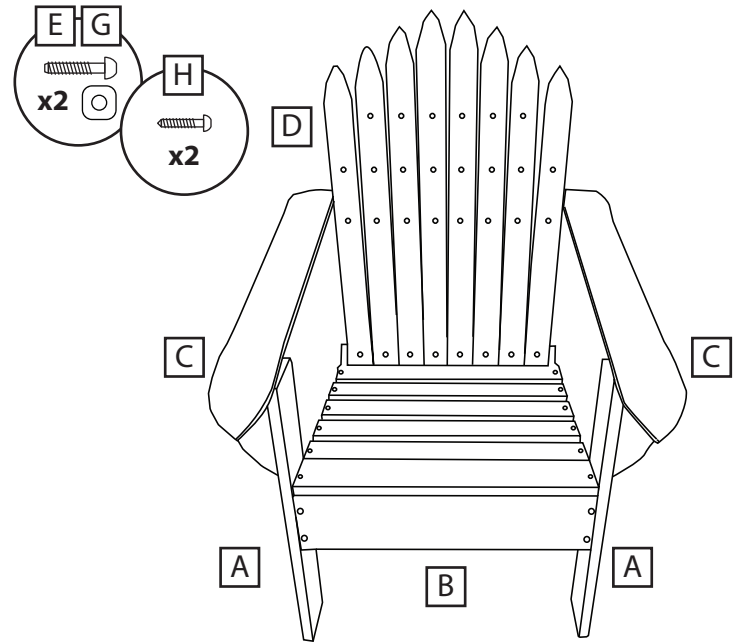

**4** Fully tighten all bolts and screws with phillips head screwdriver and included (I) Wrench.

Scan the QR code or visit the web address directly to view the **assembly video**: [displaybuilds.com/instructions\\_17783](https://displaybuilds.com/instructions_17783)



## MISSING PARTS / DAMAGE CLAIM INSTRUCTIONS

### 1. **DO NOT** discard the box or original packaging.

In the case of damaged goods caused by shipping, photo evidence will be required.

### 2. **Take photos of the box & markings.**

A photo of the markings (text) on the side of the box is required for all cases in which a replacement part is needed. This helps to identify the item number and ensures the correct parts are pulled.

### 3. **Take photos of damage (if applicable).**

A photo of the damaged part(s) is always required to file a claim and expediently process the replacement part. Please make sure you keep the box even if it is damaged.

### 4. **Send an email with the images requested.**

Email a description of the claim along with the images required above at [displaybuilds.com/contact](https://displaybuilds.com/contact) or directly to [help@displaybuilds.com](mailto:help@displaybuilds.com). Call our toll-free number 1-866-308-8368 for further assistance.