

Founders Display - Assembly Instructions

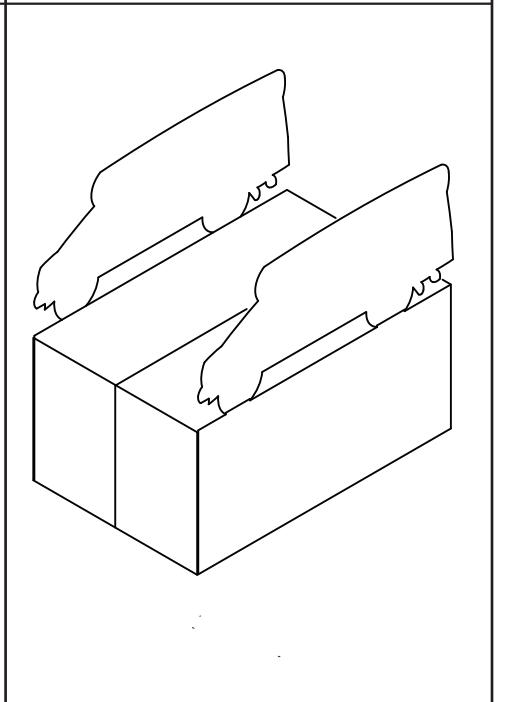

Scan the QR code or visit the web address directly to view the **assembly video**: displaybuilds.com/instructions_17882

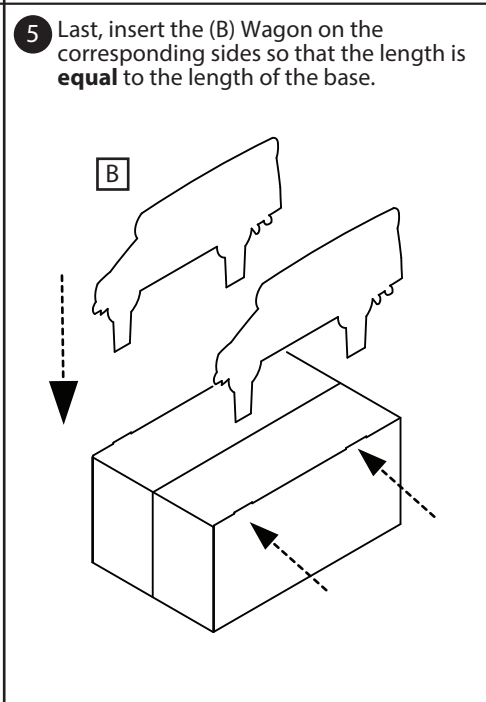

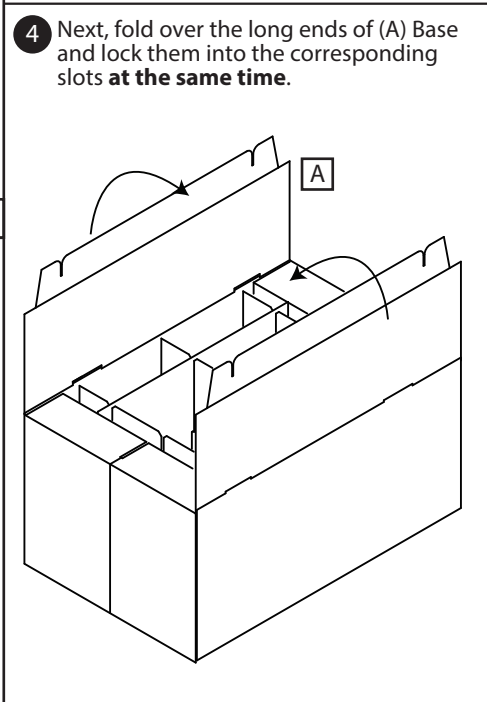
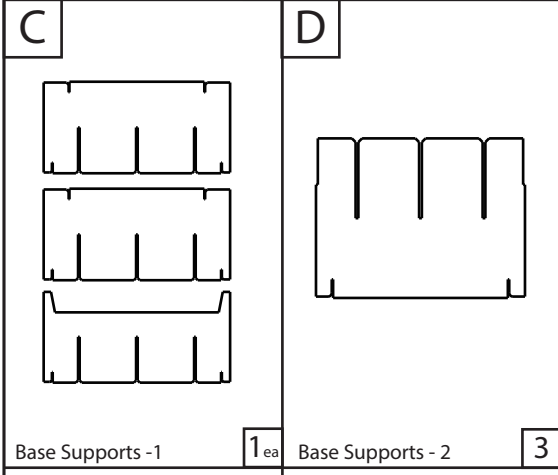
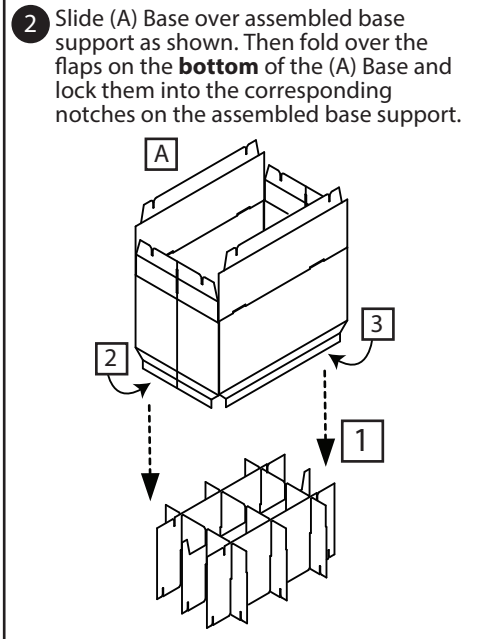
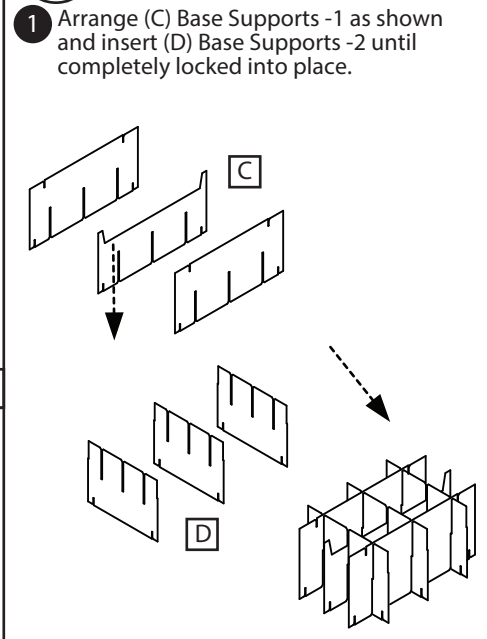
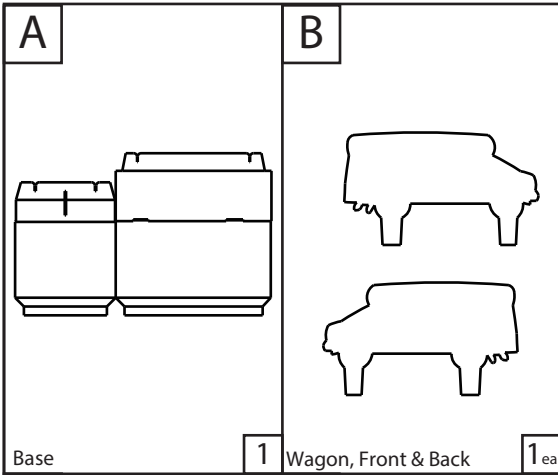

Scan the QR code or visit the web address directly to view the **assembly video**: displaybuilds.com/instructions_17882



MISSING PARTS / DAMAGE CLAIM INSTRUCTIONS

1. **DO NOT** discard the box or original packaging.

In the case of damaged goods caused by shipping, photo evidence will be required.

2. **Take photos of the box & markings.**

A photo of the markings (text) on the side of the box is required for all cases in which a replacement part is needed. This helps to identify the item number and ensures the correct parts are pulled.

3. **Take photos of damage (if applicable).**

A photo of the damaged part(s) is always required to file a claim and expediently process the replacement part. Please make sure you keep the box even if it is damaged.

4. **Send an email with the images requested.**

Email a description of the claim along with the images required above at displaybuilds.com/contact or directly to help@displaybuilds.com. Call our toll-free number 1-866-308-8368 for further assistance.