

{Your Brand} Display - Assembly Instructions

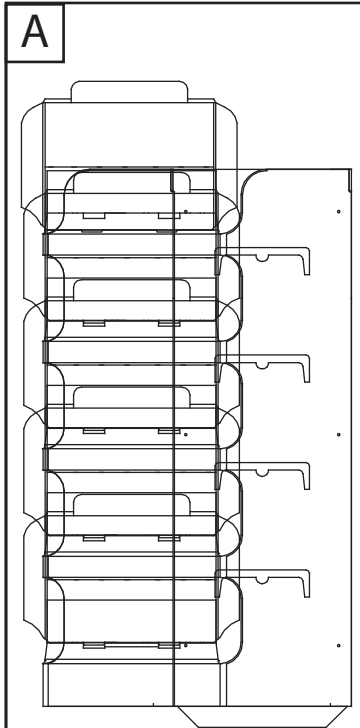

Scan the QR code or visit the web address directly to view the **assembly video**: displaybuilds.com/your-brand-display



Display Body 1

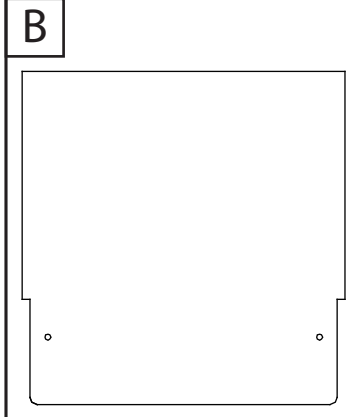

Header 1

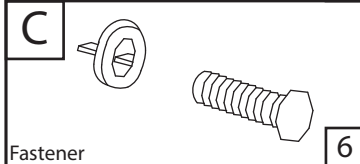

Fastener 6

1 Square up (A) Display Body. Fold tabs at sides and back of shelves down, then insert the shelf into the body angled up at the back.

Lock the **front** of the shelf into place first, then slowly push down on the back of the shelf while pushing the tab on the back of the body inward - **BUT DO NOT FOLD THIS TAB**. Insert the tab on the back of the shelf in the slot in the back of the body.

Note that the bottom shelf just pushes down into the body without being inserted into a tab on the body.

CREASE AND FOLD WITH EXTREME CARE.

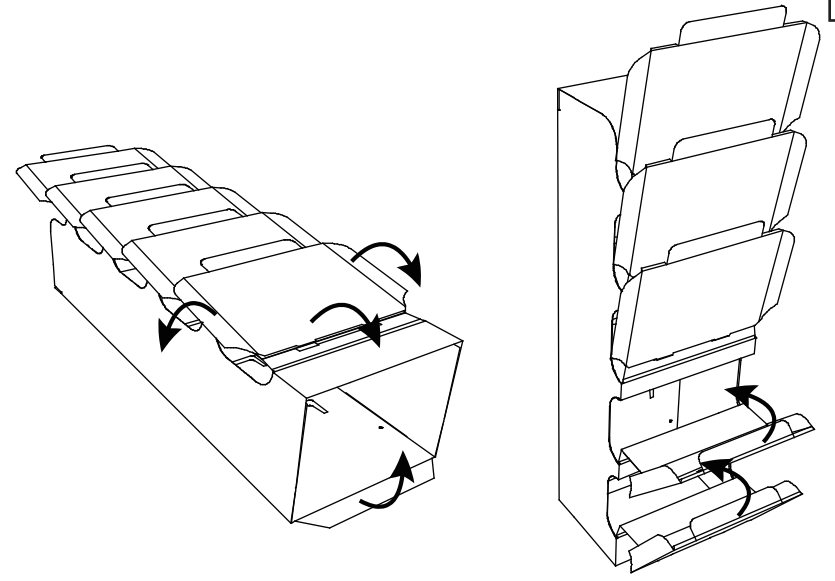

2 Insert (B) Header.

i To install two displays back to back, insert a (C) Fastener through both displays at the 6 indicated locations, and secure with a wingnut.

Scan the QR code or visit the web address directly to view the **assembly video**: displaybuilds.com/your-brand-display



MISSING PARTS / DAMAGE CLAIM INSTRUCTIONS

1. **DO NOT** discard the box or original packaging.

In the case of damaged goods caused by shipping, photo evidence will be required.

2. **Take photos of the box & markings.**

A photo of the markings (text) on the side of the box is required for all cases in which a replacement part is needed. This helps to identify the item number and ensures the correct parts are pulled.

3. **Take photos of damage (if applicable).**

A photo of the damaged part(s) is always required to file a claim and expediently process the replacement part. Please make sure you keep the box even if it is damaged.

4. **Send an email with the images requested.**

Email a description of the claim along with the images required above at displaybuilds.com/contact or directly to help@displaybuilds.com. Call our toll-free number 1-866-308-8368 for further assistance.