

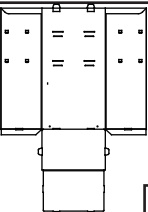

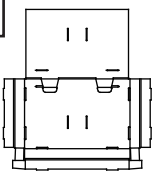

Dr Pepper / Big Lots Football Display - Assembly Instructions

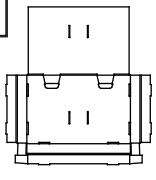
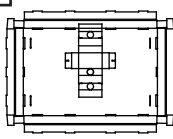
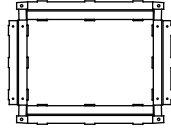

Scan the QR code or visit the web address directly to view the **assembly video**: displaybuilds.com/instructions_17896

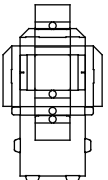
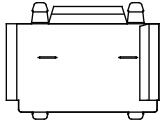
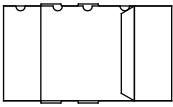
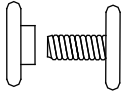

<p>A</p>  <p>Body 2</p>	<p>B</p>  <p>Shelf 1 2</p>	<p>C</p>  <p>Shelf 2 2</p>	<p>D</p>  <p>Top Tray 1</p>	<p>E</p>  <p>Bottom Center Tray 1</p>	<p>F</p>  <p>Tray Liner 1</p>
<p>G</p>  <p>Header 1</p>	<p>H</p>  <p>Filler Box 2</p>	<p>I</p>  <p>Spacer Box 2</p>	<p>J</p>  <p>Fastener 4</p>	<p>K</p>  <p>Support Bar 8</p>	<p>L</p>  <p>Header Tube 1</p>

1 Assemble all (B) Shelf 1 and (C) Shelf 2 by folding as shown below.

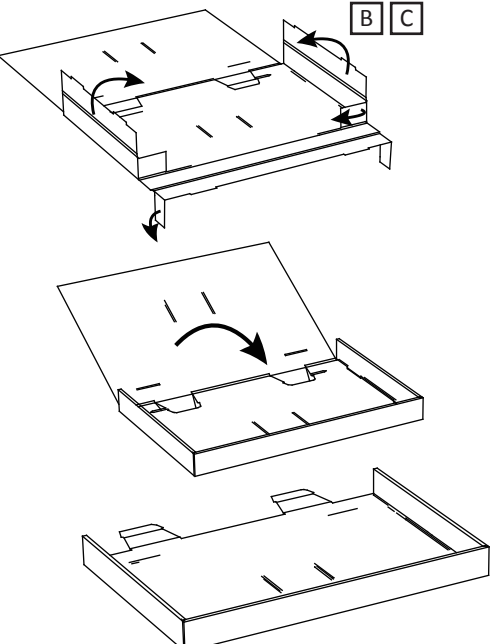

2 Assemble (E) Bottom Center Tray by folding as shown below. Then place (F) Tray Liner in the bottom.

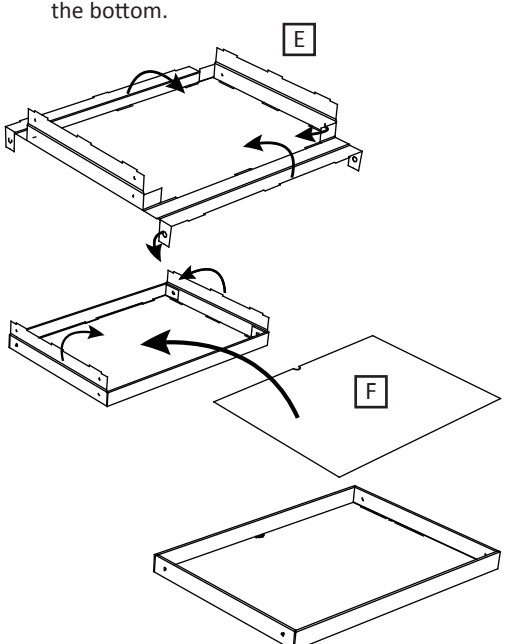

3 Assemble (D) Top Tray by folding as shown below.

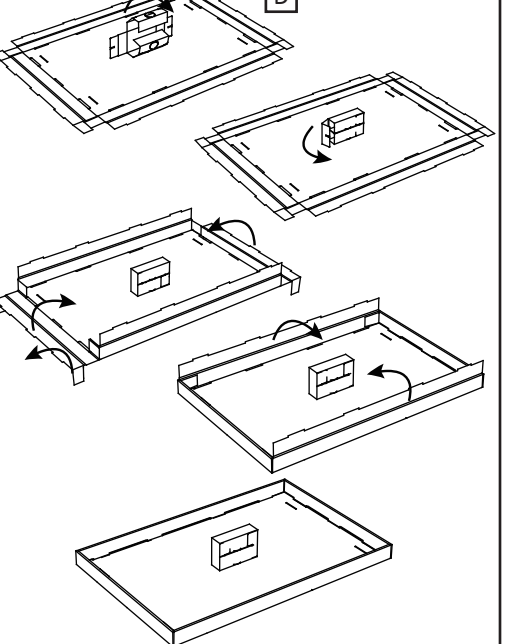

4 Assemble (G) Header by folding as shown below.

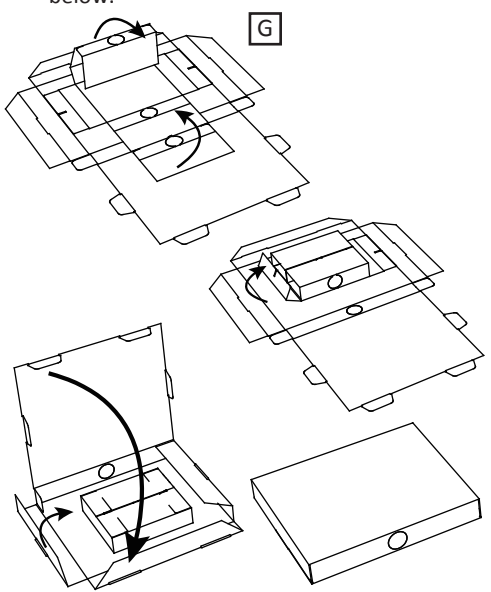

5 Assemble both (A) Body structures as shown below. Install (K) Support Bars in each.

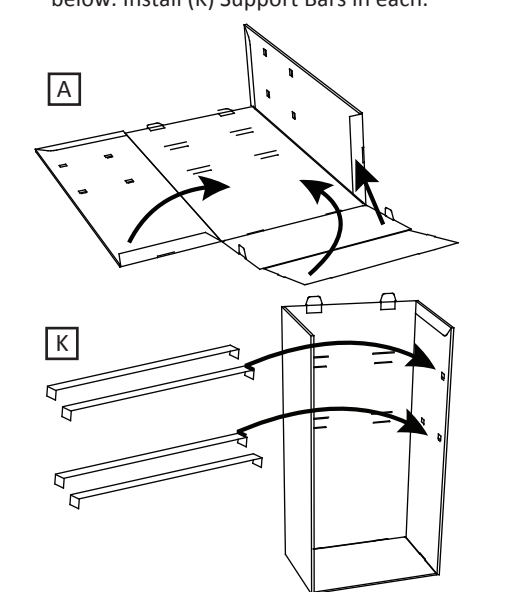

6 Insert the tabs at the back of (B) Shelf 1 in the top slots and (C) Shelf 2 in the top set of second slots. Assemble and insert (I) Spacer Box between the two shelves.

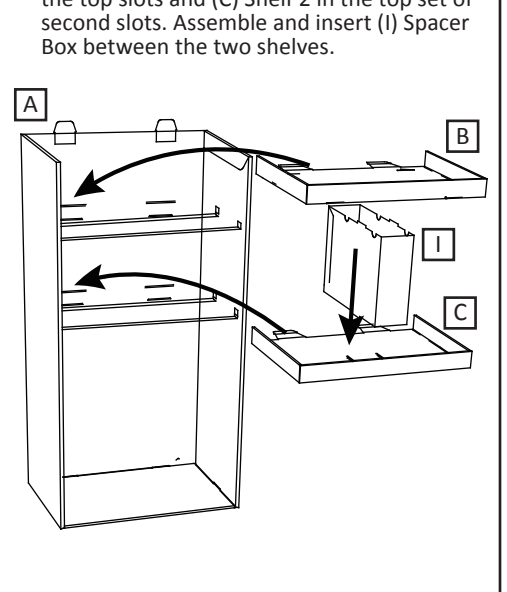

Dr Pepper / Big Lots Football Display - Assembly Instructions

Scan the QR code or visit the web address directly to view the **assembly video**: displaybuilds.com/instructions_17896



- 7** Finalize shelf installation by folding the shelf tabs down and insert back through the second slot on the back of each (A) Body to lock them into place.

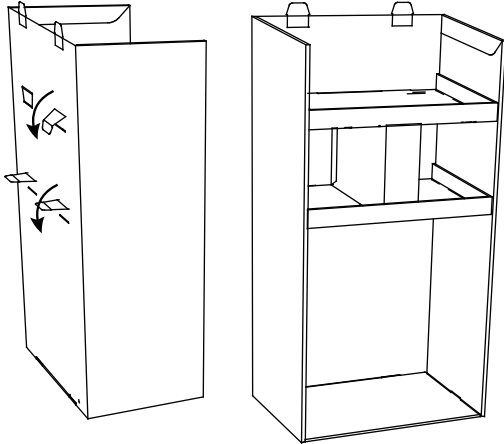

- 8** Assemble and insert (H) Filler Box into each (A) Body and (B) Shelf 1. Insert tabs at the back of the (A) Body into the (H) Filler Box.

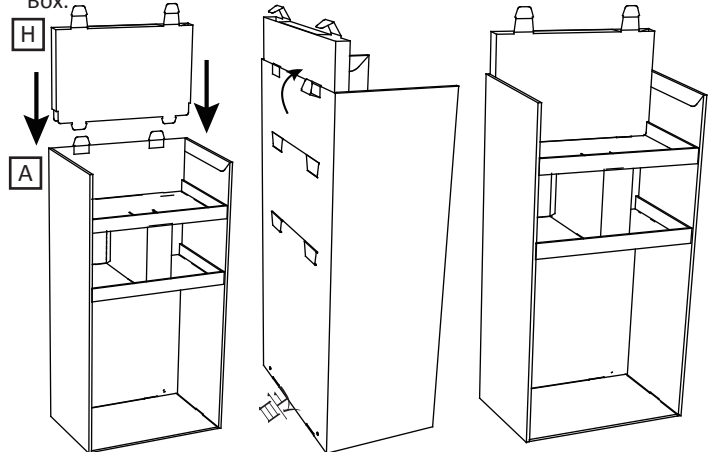

- 9** Arrange assembled displays and components as shown. Attach the (D) Top Tray with the (H) Filler Box tabs. Insert (L) Header Tube and then assembled (G) Header. Fasten (E) Bottom Center Tray to each (A) Body with (J) Fasteners.

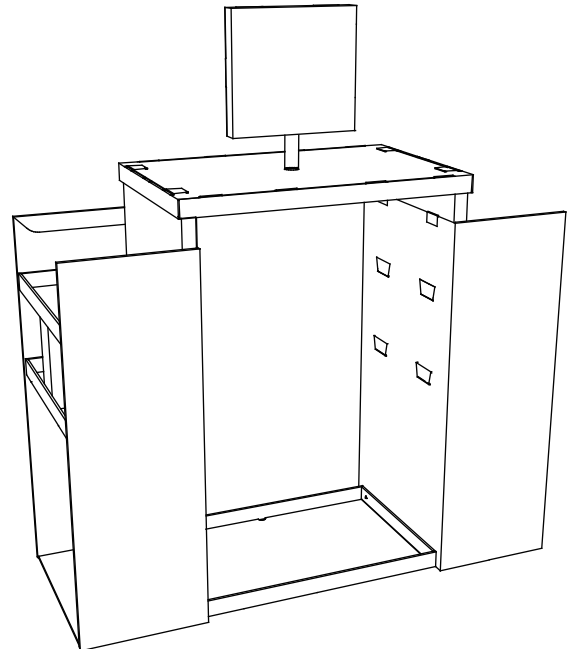
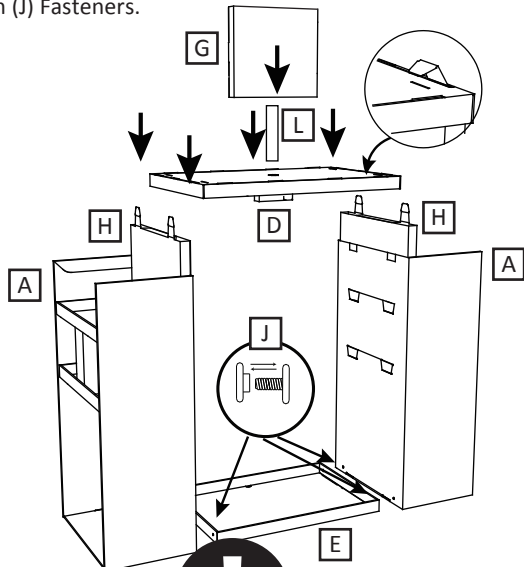

MISSING PARTS / DAMAGE CLAIM INSTRUCTIONS

1. DO NOT discard the box or original packaging.

In the case of damaged goods caused by shipping, photo evidence will be required.

2. Take photos of the box & markings.

A photo of the markings (text) on the side of the box is required for all cases in which a replacement part is needed. This helps to identify the item number and ensures the correct parts are pulled.

3. Take photos of damage (if applicable).

A photo of the damaged part(s) is always required to file a claim and expediently process the replacement part. Please make sure you keep the box even if it is damaged.

4. Send an email with the images requested.

Email a description of the claim along with the images required above at displaybuilds.com/contact or directly to help@displaybuilds.com. Call our toll-free number 1-866-308-8368 for further assistance.