

KDP Flavors Ambient Display - Assembly Instructions

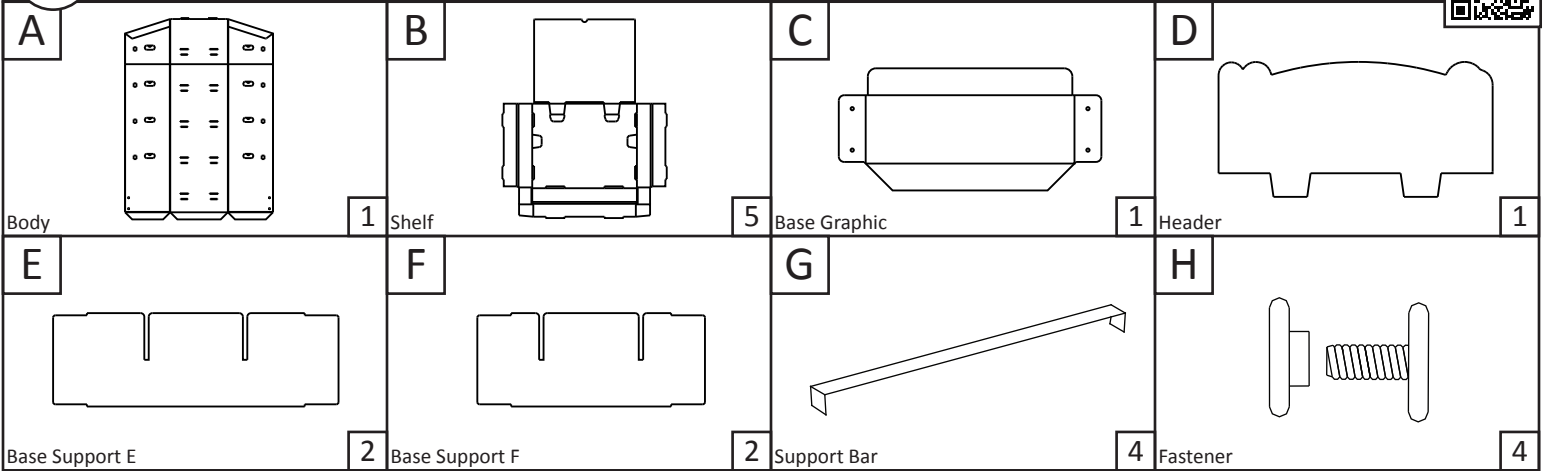

Scan the QR code or visit the web address directly to view the **assembly video**: displaybuilds.com/instructions_17942



1 Open up (A) Body, fold the bottom flaps under and inward, and stand up.

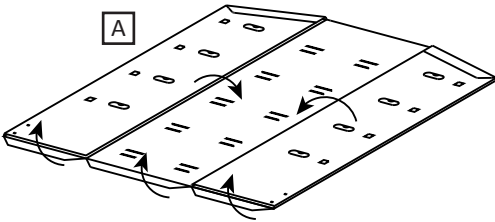

2 Attach (C) Base Graphic to (A) Body with x4 (H) Fasteners.

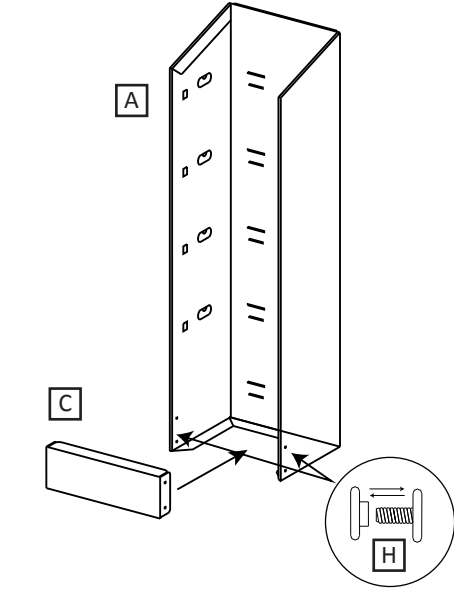

3 Assemble (E & F) Base Supports as shown and place in bottom of (A) Body.

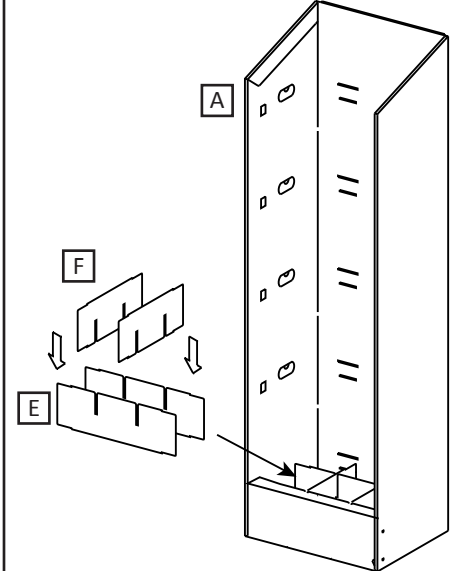

4 Install (G) Support Bars by inserting into the corresponding slots in the (A) Body.

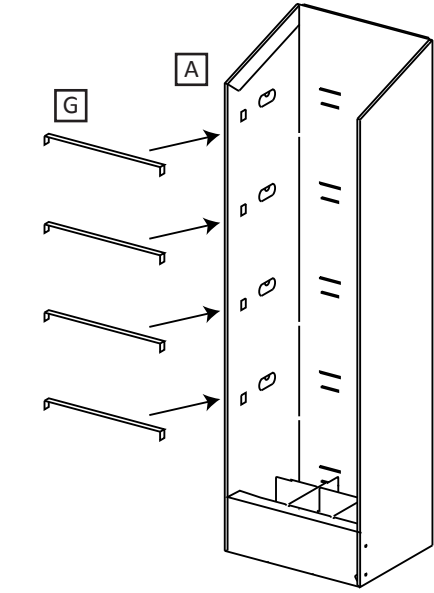

5 Assemble x5 (B) Shelves by folding as shown.

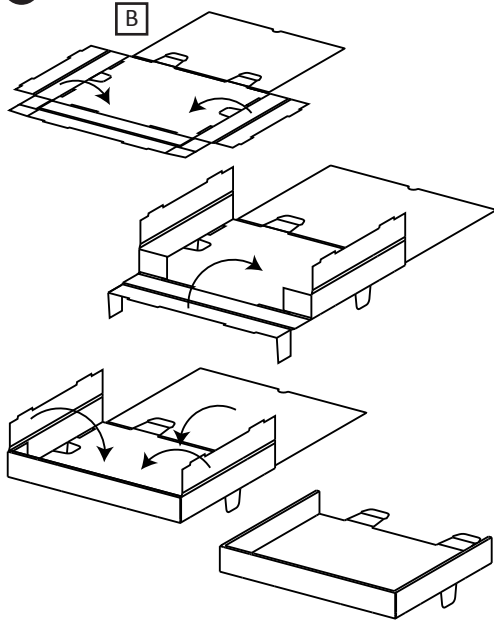

6 Install each (B) Shelf in the order shown by inserting the tab through the top slot in the back of the (A) Body, and the side tabs into the side of the (A) Body for each shelf location.

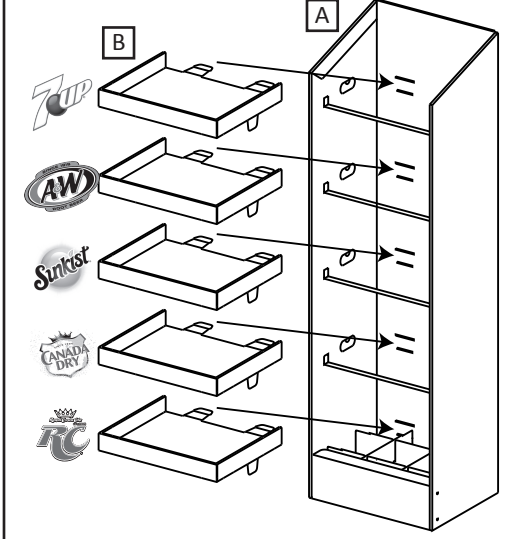

KDP Flavors Ambient Display - Assembly Instructions



Scan the QR code or visit the web address directly to view the **assembly video**: displaybuilds.com/instructions_17942



7 Lock (B) Shelves into place by folding the tab at the back down and inserting it in the bottom slot of the (A) Body.

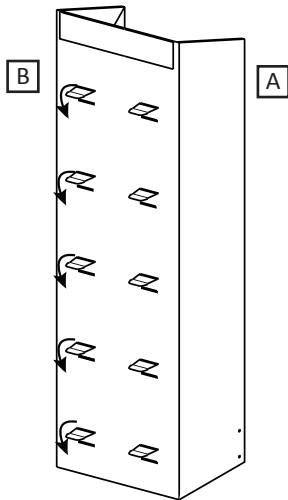

8 Insert (D) Header.

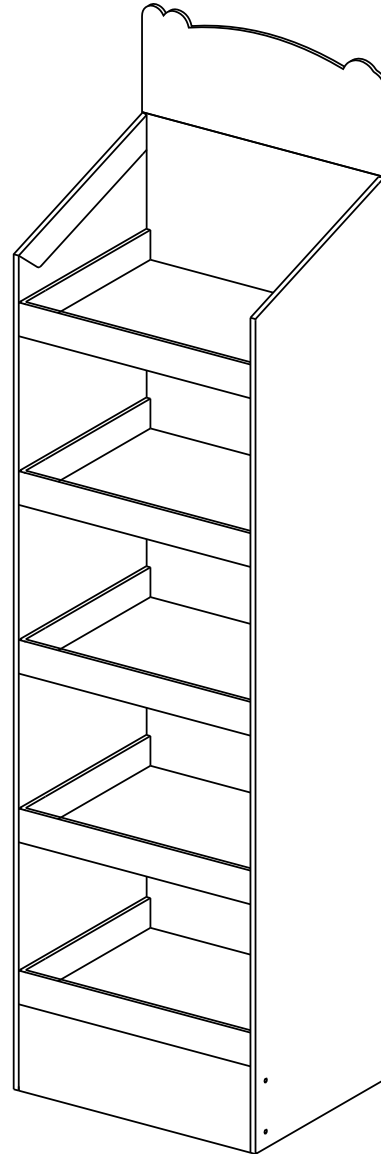
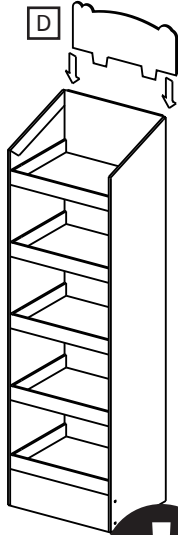

MISSING PARTS / DAMAGE CLAIM INSTRUCTIONS

1. DO NOT discard the box or original packaging.

In the case of damaged goods caused by shipping, photo evidence will be required.

2. Take photos of the box & markings.

A photo of the markings (text) on the side of the box is required for all cases in which a replacement part is needed. This helps to identify the item number and ensures the correct parts are pulled.

3. Take photos of damage (if applicable).

A photo of the damaged part(s) is always required to file a claim and expediently process the replacement part. Please make sure you keep the box even if it is damaged.

4. Send an email with the images requested.

Email a description of the claim along with the images required above at displaybuilds.com/contact or directly to help@displaybuilds.com. Call our toll-free number 1-866-308-8368 for further assistance.