

Two Roads Corrugate Holiday Light Pole - Assembly Instructions



Scan the QR code or visit the web address directly to view the **assembly video**: displaybuilds.com/instructions_18096



<p>A</p> <p>Base 1</p>	<p>B</p> <p>Pole 1</p>	<p>C</p> <p>Light Base 1</p>	<p>D</p> <p>Light Top 1</p>	<p>E</p> <p>Hanging Sign 1</p>	<p>F</p> <p>Poster 1</p>
<p>G</p> <p>Base Support 4</p>	<p>H</p> <p>Short Metal Bar 1</p>				
<p>1 Assemble (G) Base Supports as shown.</p>		<p>2 Square up (A) Base and insert assembled (G) Base Supports as shown.</p>		<p>3 Fold bottom flaps on (A) Base over and in to lock into the (G) Base Support structure.</p>	
<p>4 Stand the assembled (A) Base Bin up. Fold the small top flaps inward first, then fold and lock the larger top flaps into place.</p>		<p>5 Assemble (B) Pole and lock side tabs into place.</p>		<p>6 Begin assembly of the (D) Light Top by folding up the two sides with the long end flaps first, then fold up the other two sides.</p>	
<p>7 Finalize (D) Light Top assembly by locking tabs into place at the sides and top.</p>		<p>8 Assemble (C) Light Base by folding up all sides, then wrapping them around the center piece and locking each tab into place.</p>		<p>9 Finalize assembly of the (C) Light Base by locking the final panel into the center piece and with the sides tabs.</p>	

Two Roads Corrugate Holiday Light Pole - Assembly Instructions



Scan the QR code or visit the web address directly to view the **assembly video**: displaybuilds.com/instructions_18096



- 7** Attach (C) Light Base to (B) Pole and lock tabs into place.

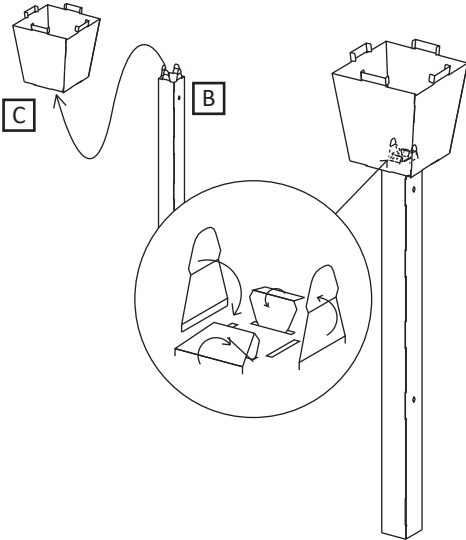

- 8** Attach (D) Light Top to (C) Light Base and lock u-shaped flaps into place.

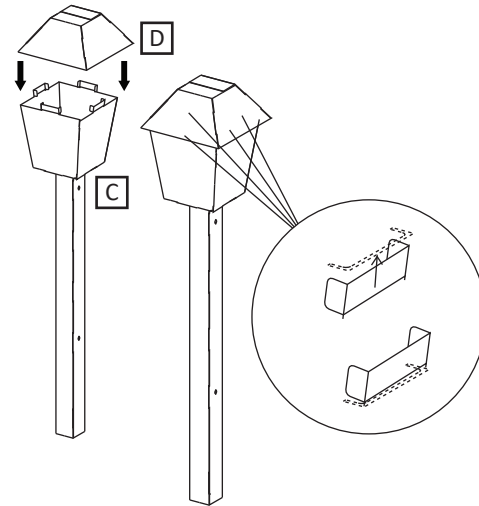

- 9** Insert assembled light pole into assembled (A) Base.

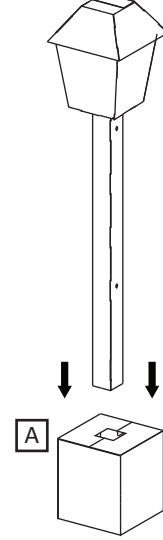

- 10** Insert (E) Hanging Sign and (H) Short Metal Bar into (B) Pole.

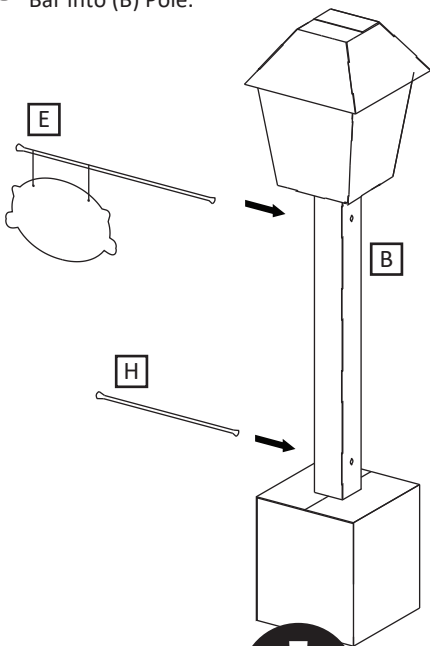

- 11** Attach (F) Poster to both bars on the opposite side of the (B) Pole.

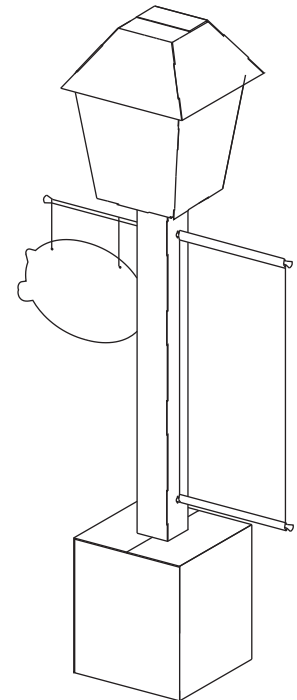
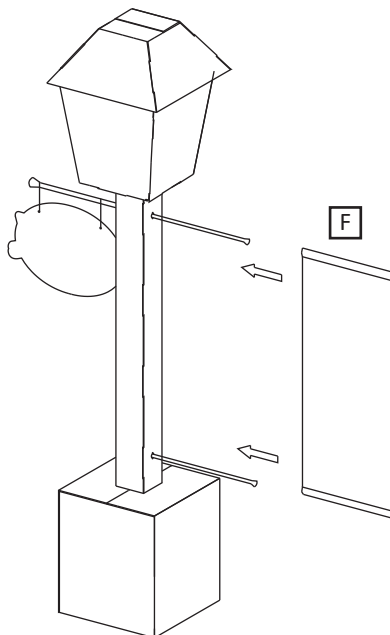

MISSING PARTS / DAMAGE CLAIM INSTRUCTIONS

- 1. DO NOT** discard the box or original packaging.

In the case of damaged goods caused by shipping, photo evidence will be required.

- 2. Take photos of the box & markings.**

A photo of the markings (text) on the side of the box is required for all cases in which a replacement part is needed. This helps to identify the item number and ensures the correct parts are pulled.

- 3. Take photos of damage (if applicable).**

A photo of the damaged part(s) is always required to file a claim and expediently process the replacement part. Please make sure you keep the box even if it is damaged.

- 4. Send an email with the images requested.**

Email a description of the claim along with the images required above at displaybuilds.com/contact or directly to help@displaybuilds.com. Call our toll-free number 1-866-308-8368 for further assistance.