

KDP Favorite Flavors Display - Assembly Instructions

JOB 18321
NOCD

Scan the QR code or visit the web address directly to view the assembly video: displaybuilds.com/instructions_18321

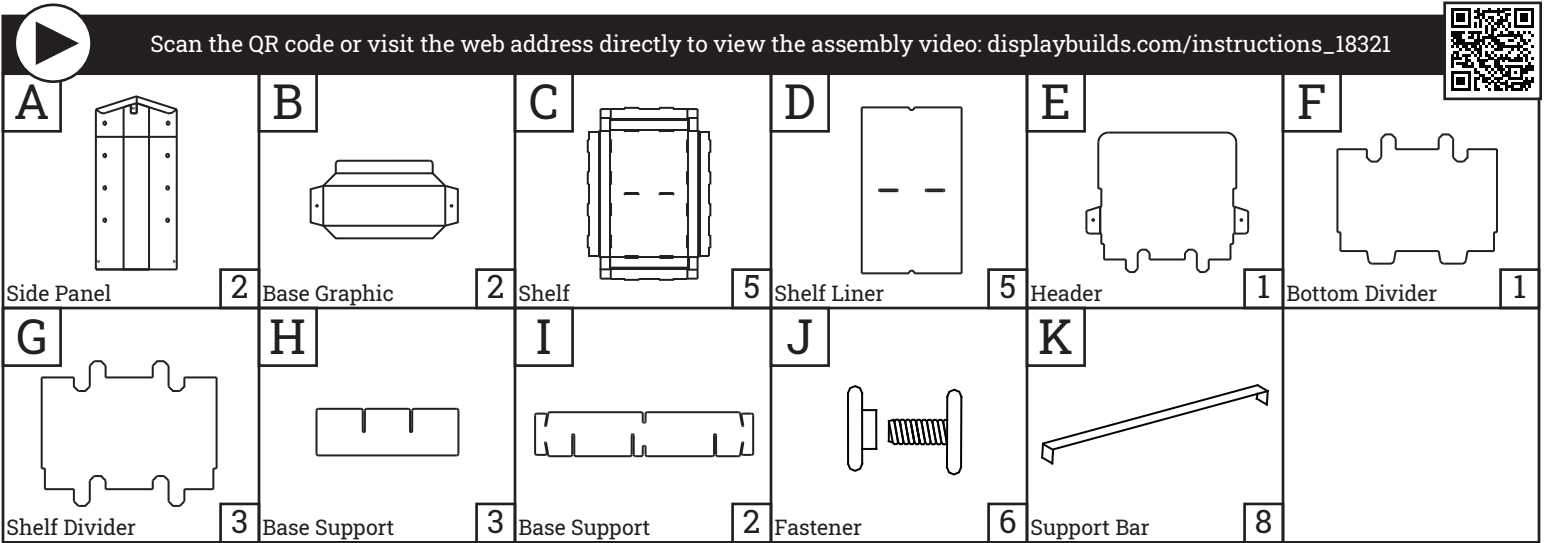

1 Assemble all (C) Shelves by folding as shown. Insert (D) Shelf Liner to finalize.

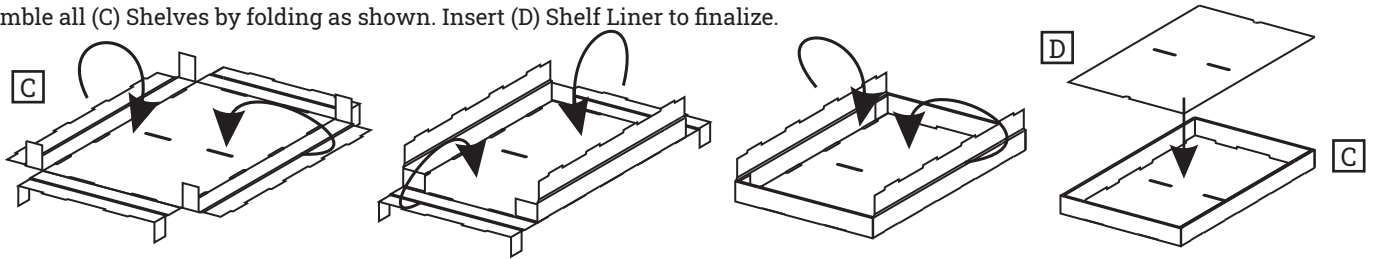

2 Attach both (B) Base Graphics to each (A) Side Panel using (J) Fasteners.

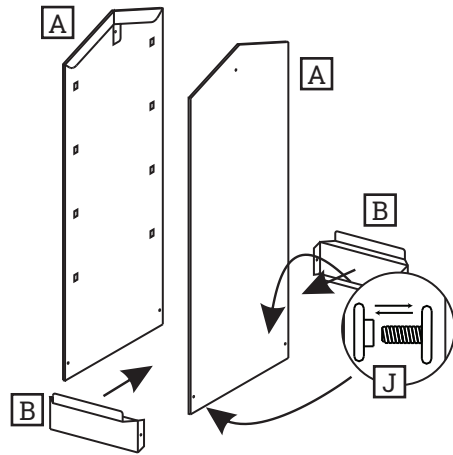

3 Assemble base structure by crossing and interlocking (H) and (I) Base Supports as shown and place inside display.

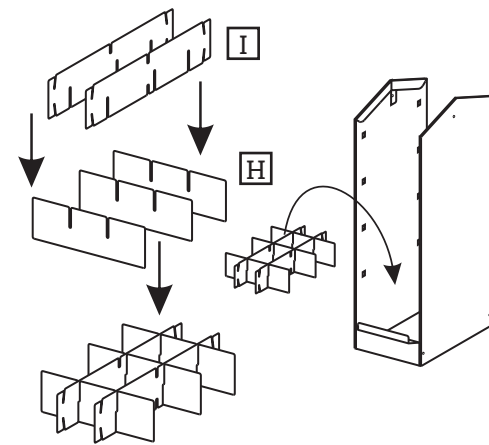

4 Fold over both (B) Base Graphics and lock them into the (I) Base Supports.

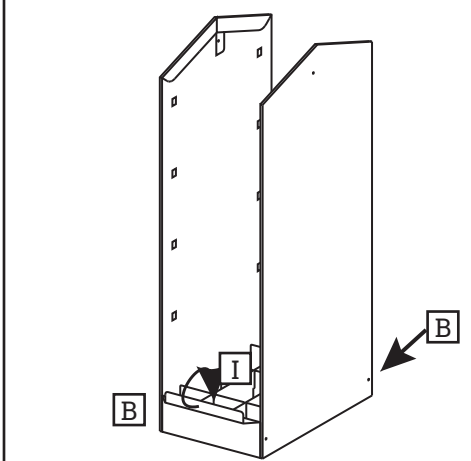

5 Place one of the assembled (C) Shelves on top of the assembled (H) & (I) Base Supports. Note the front logo below; the Sunkist logo will be on the back side.

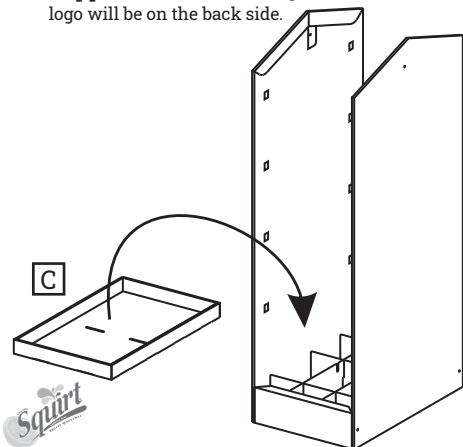

6 Insert the (F) Bottom Divider into the slots on the (C) Shelf.

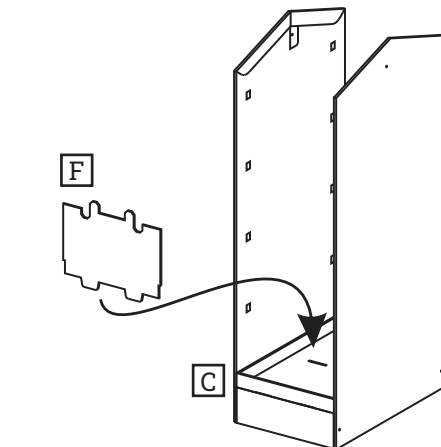

7 Install x2 (K) Support Bars into the lowest slots on the (A) Side Panels as shown.

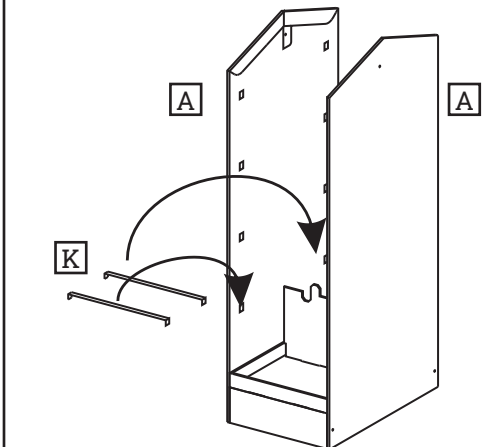

KDP Favorite Flavors Display - Assembly Instructions

JOB 18321
NOCD

Scan the QR code or visit the web address directly to view the assembly video: displaybuilds.com/instructions_18321



8 Place an assembled (C) Shelf on top of the (F) Bottom Divider and (K) Support Bars and insert the tabs into the slots on the (C) Shelf.

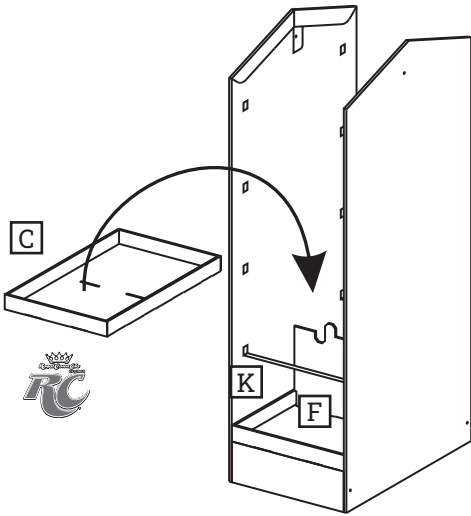

9 Insert a (G) Shelf Divider into the slots on the (C) Shelf and interlock with the tabs on the (F or G) Divider below.

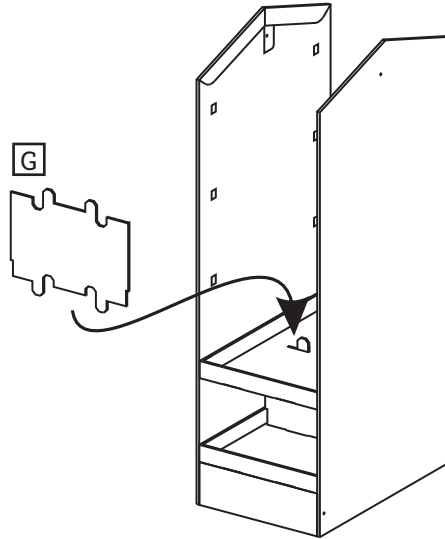

10 Repeat steps 7 through 9 twice to continue building the layers of the display.

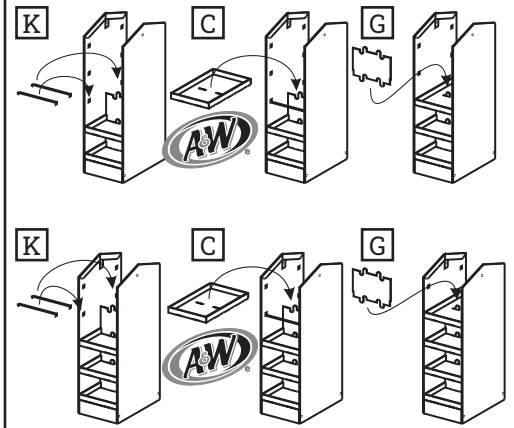

11 Repeat steps 7-8 to install the last (K) Support Bars and top (C) Shelf.

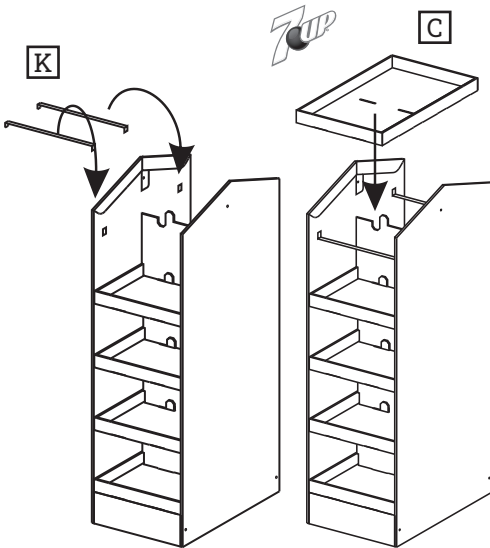

12 Interlock the (E) Header with the (C) Shelf and (G) Shelf Divider tabs with the logos corresponding to the shelves.

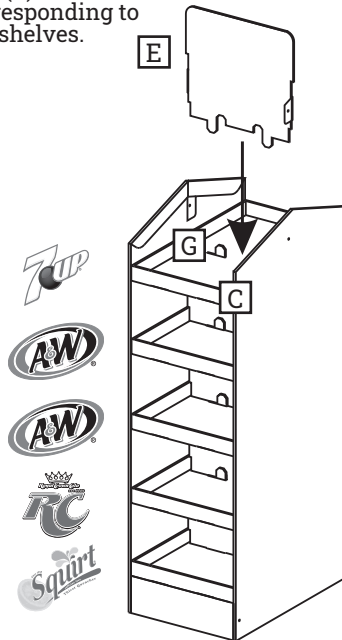

13 Fold the tabs on the side of the (E) Header to align with the slots in the (A) Side Panels. Secure with (J) Fasteners.

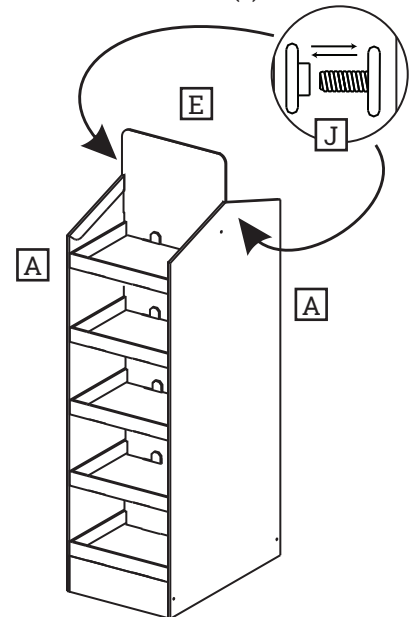

MISSING PARTS / DAMAGE CLAIM INSTRUCTIONS

- DO NOT** discard the box or original packaging.
In the case of damaged goods caused by shipping, photo evidence will be required.
- Take photos of the box & markings.
A photo of the markings (text) on the side of the box is required for all cases in which a replacement part is needed. This helps to identify the item number and ensures the correct parts are pulled.
- Take photos of damage (if applicable).
A photo of the damaged part(s) is always required to file a claim and expediently process the replacement part. Please make sure you keep the box even if it is damaged.
- Send an email with the images requested.
Email a description of the claim along with the images required above at displaybuilds.com/contact or directly to help@displaybuilds.com. Call our toll-free number 1-866-308-8368 for further assistance.