

# Absolut Corrugate Display - Assembly Instructions

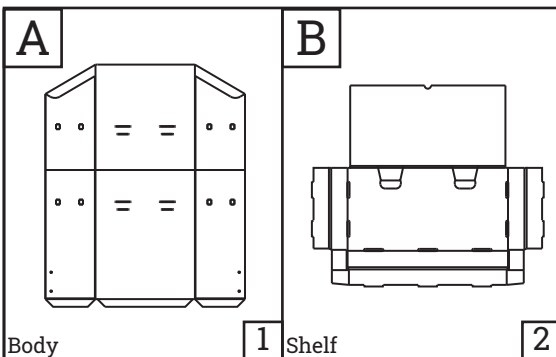

Scan the QR code or visit the web address directly to view the assembly video: [displaybuilds.com/instructions\\_18322](http://displaybuilds.com/instructions_18322)



**A** Body 1 **B** Shelf 2

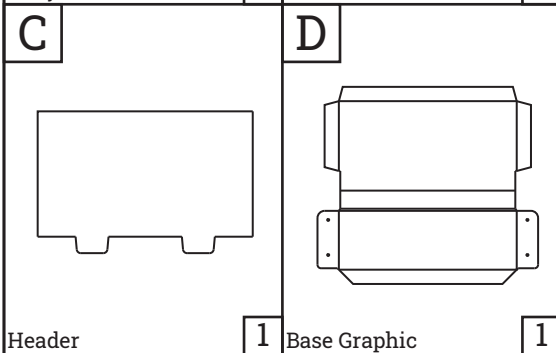

**C** Header 1 **D** Base Graphic 1

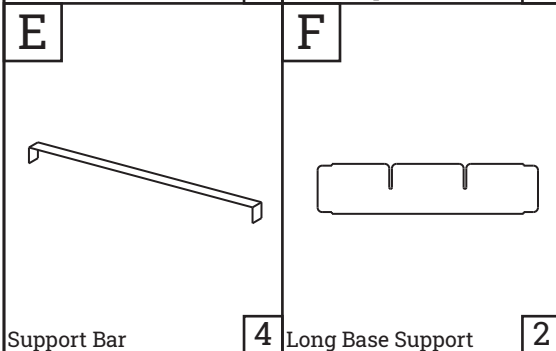

**E** Support Bar 4 **F** Long Base Support 2

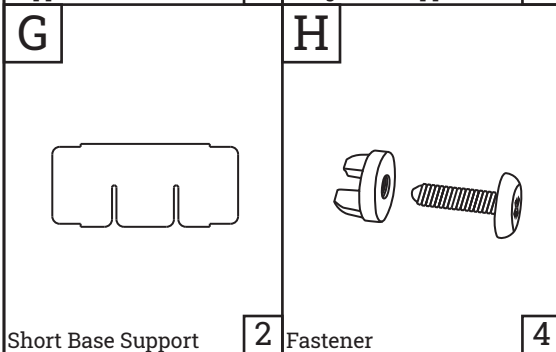

**G** Short Base Support 2 **H** Fastener 4

**1** Square up (A) Body and fold bottom flaps inward.

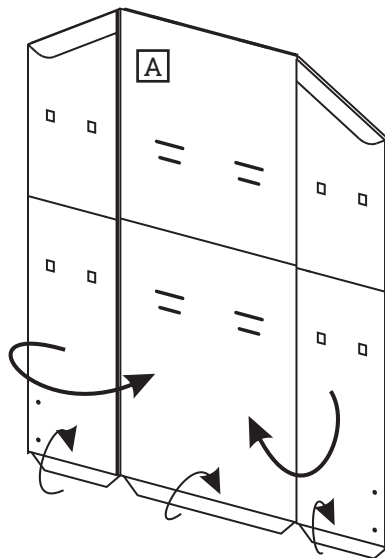

**2** Attach (D) Base Graphic to (A) Body with (H) Fasteners.

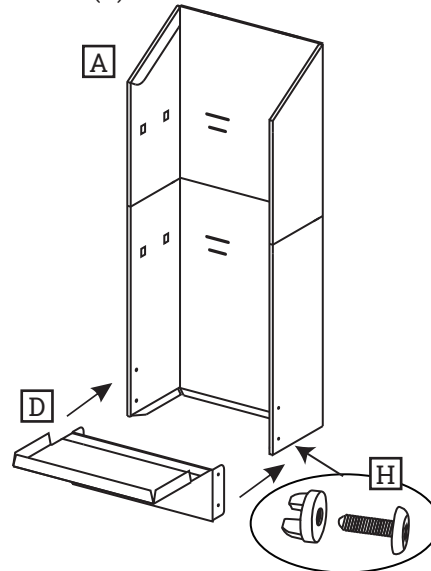

**3** Cross (F) and (G) Base Supports as shown and interlock together. Insert into the base behind the (D) Base Graphic.

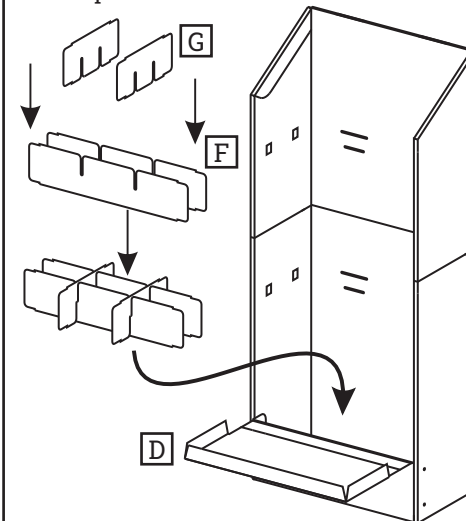

**4** Fold over (D) Base Graphic to form a lip, and then tuck in the bottom to form a shelf.

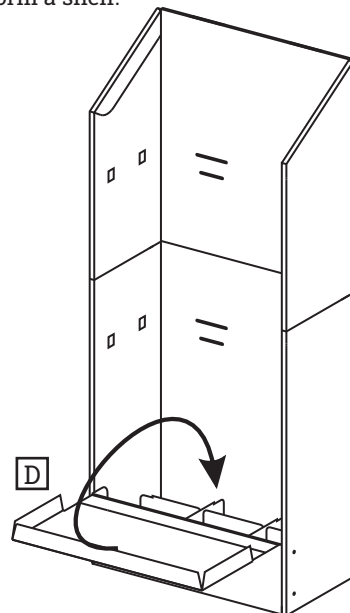

**5** Assemble (B) Shelves by folding as shown.

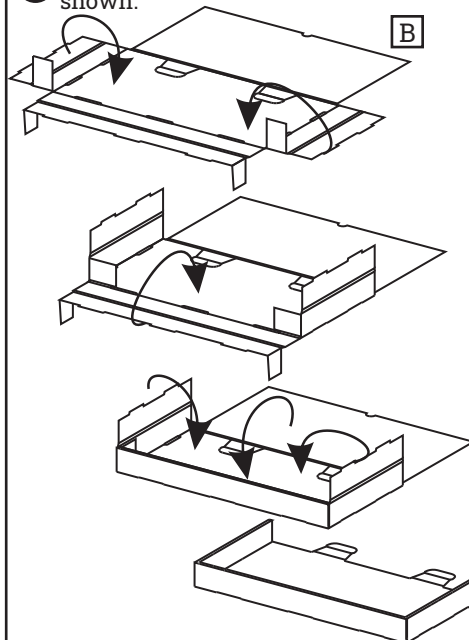

**6** Insert (E) Support Bars into (A) Body at corresponding slots.

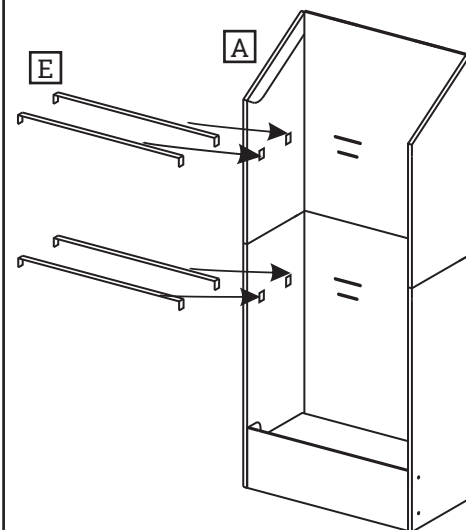

# Absolut Corrugate Display - Assembly Instructions

Scan the QR code or visit the web address directly to view the assembly video: [displaybuilds.com/instructions\\_18322](http://displaybuilds.com/instructions_18322)



**7** Install the assembled (B) Shelves by inserting the tab at the back into the corresponding TOP slot at the back of the (A) Body and resting the front of the shelf on the (E) Support Bars. Then lock the each (B) Shelf into place by folding the tab at the back of the display down and inserting into the bottom slot.

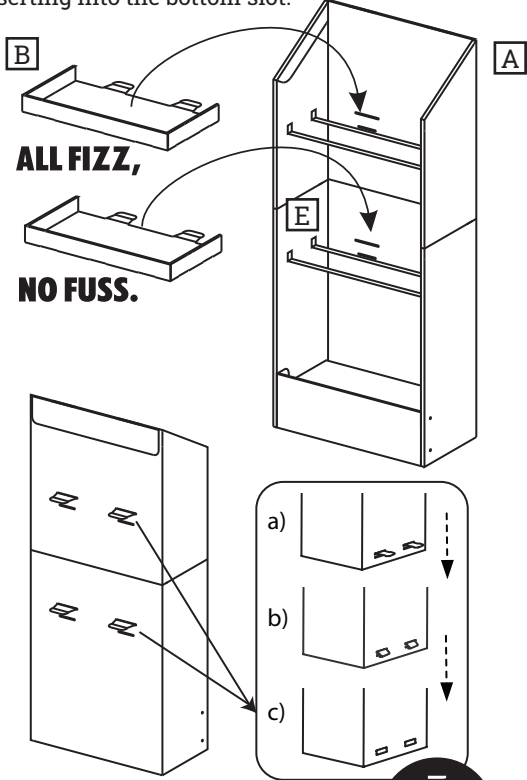

**8** Insert (C) Header into (A) Body.

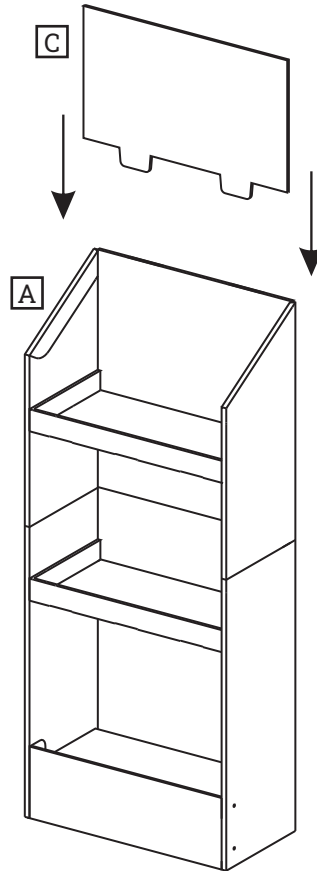

## MISSING PARTS / DAMAGE CLAIM INSTRUCTIONS

1. DO NOT discard the box or original packaging.  
In the case of damaged goods caused by shipping, photo evidence will be required.
2. Take photos of the box & markings.  
A photo of the markings (text) on the side of the box is required for all cases in which a replacement part is needed. This helps to identify the item number and ensures the correct parts are pulled.
3. Take photos of damage (if applicable).  
A photo of the damaged part(s) is always required to file a claim and expediently process the replacement part. Please make sure you keep the box even if it is damaged.
4. Send an email with the images requested.  
Email a description of the claim along with the images required above at [displaybuilds.com/contact](http://displaybuilds.com/contact) or directly to [help@displaybuilds.com](mailto:help@displaybuilds.com). Call our toll-free number 1-866-308-8368 for further assistance.