

# DG Pepsi/Coke Rolltainer - Assembly Instructions

JOB 18363

Scan the QR code or visit the web address directly to view the assembly video: [displaybuilds.com/instructions\\_18363](http://displaybuilds.com/instructions_18363)

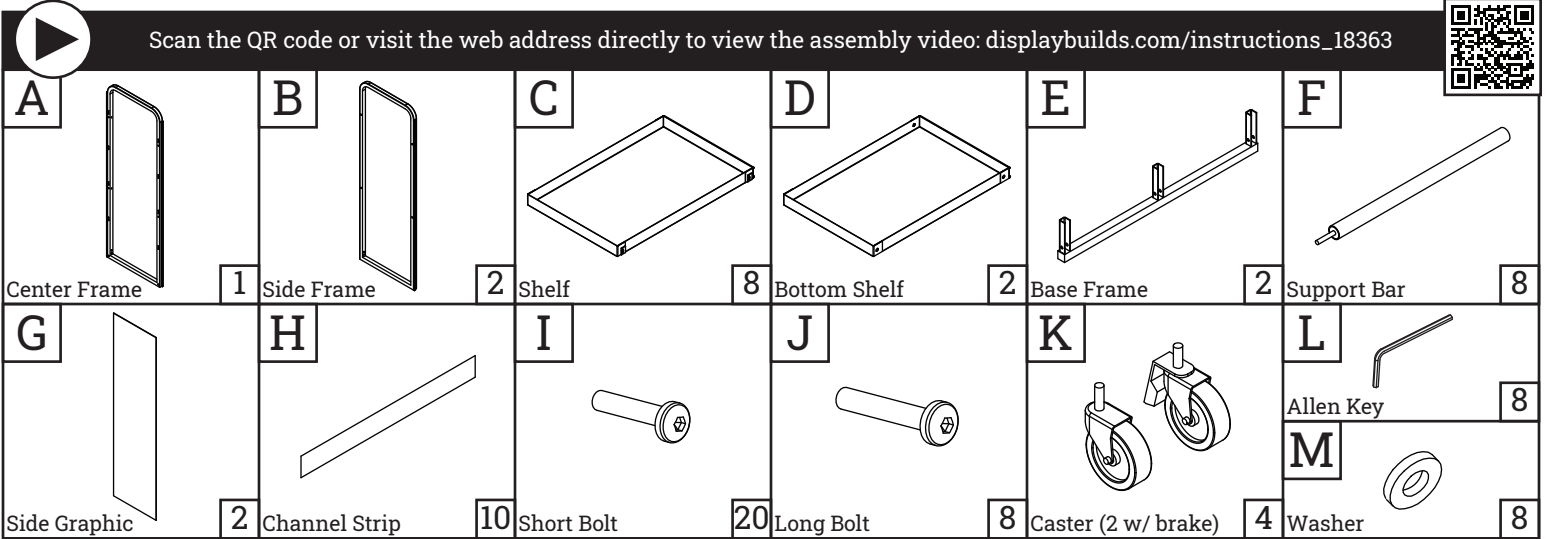

**1** Lay (A) Center Frame down and thread x4 (F) Support Bars into the frame at indicated locations.

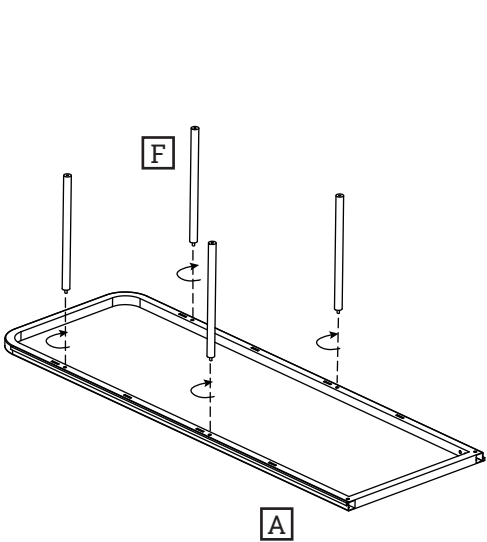

**2** Hook x4 (C) Shelves into (A) Center Frame.

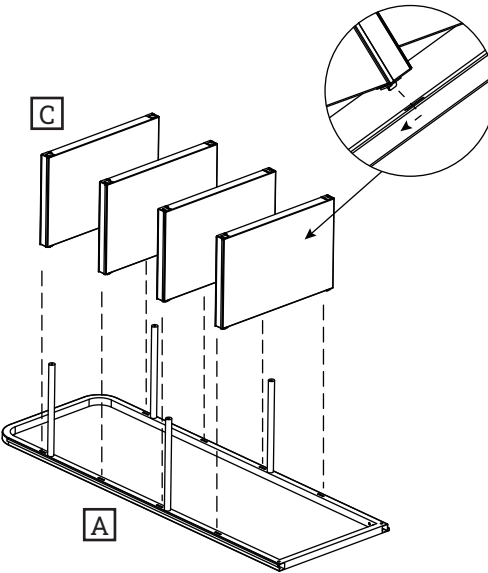

**3** Hook the x4 (C) Shelves into (B) Side Frame as shown. Then secure (B) Side Frame to (F) Support Bars using x4 (J) Long Bolts and tighten with (L) Allen Key.

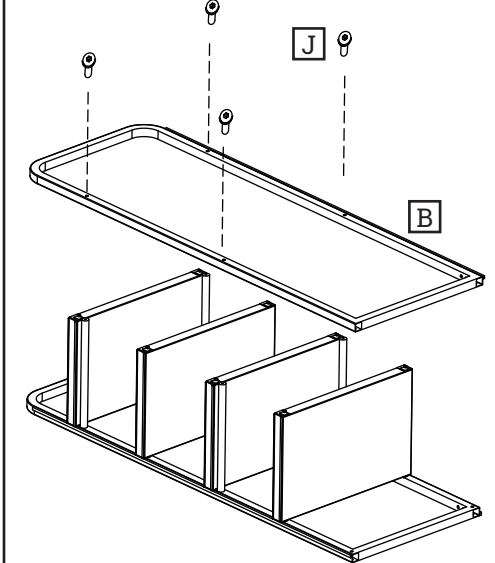

**4** Stand up, or flip display over so the opposite side is accessible. Thread x4 (F) Support Bars into (A) Center Frame on the other side. Hook x4 (C) Shelves onto (A) Center Frame.

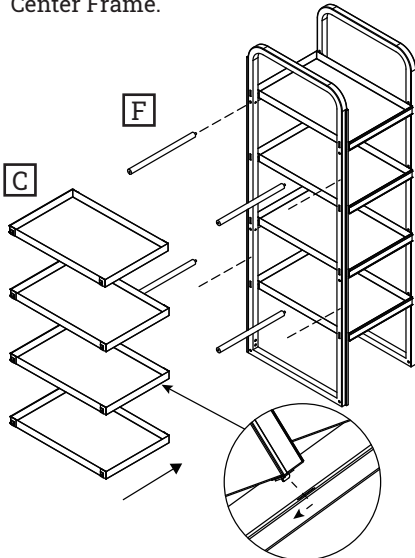

**5** Hook x4 (C) Shelves into (B) Side Frame as shown. Then secure (B) Side Frame to x4 (F) Support Bars with x4 (J) Long Bolts and tighten with (L) Allen Key.

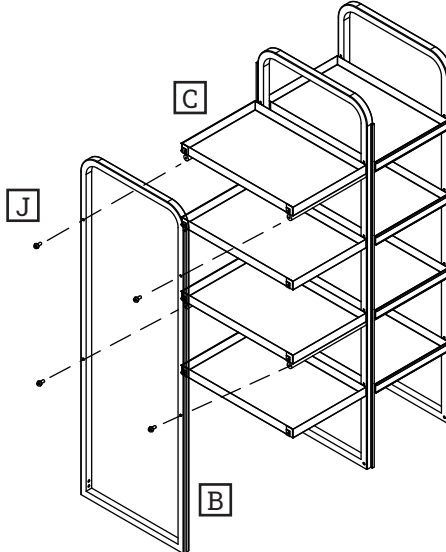

**6** Thread x4 (K) Casters into x2 (E) Base Frames.

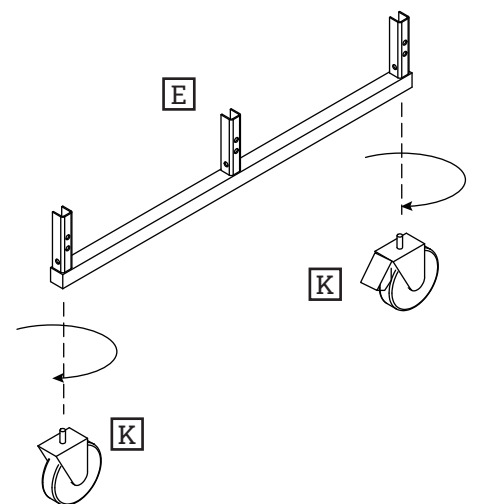



Scan the QR code or visit the web address directly to view the assembly video: [displaybuilds.com/instructions\\_18363](http://displaybuilds.com/instructions_18363)



**7** With the display laying on its side, insert x2 (E) Base Frames into (A) Center and (B) Side Frames. Secure with x12 (I) Short Bolts and tighten with (L) Allen Key. Display can now be stood upright.

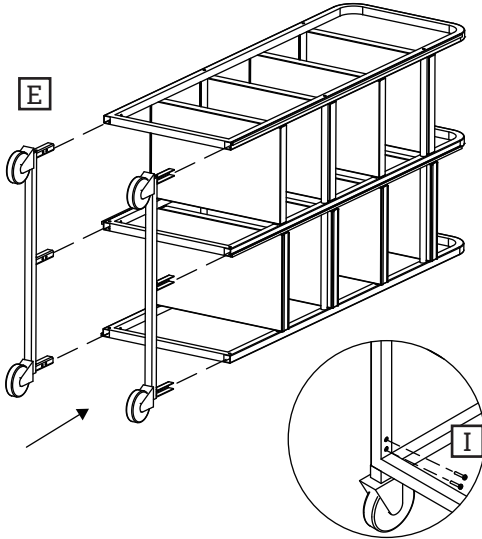

**8** Place each (D) Bottom Shelf onto the (E) Base Frames and secure with x8 (M) Washers and (I) Short Bolts, placing the washer between the SHELF and FRAME. Tighten with (L) Allen Key.

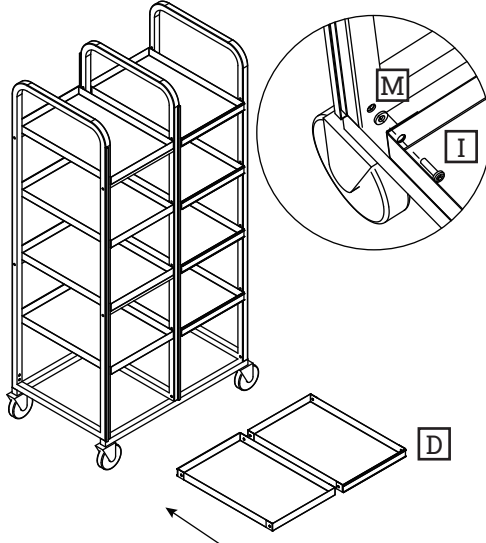

**10** Slide x2 (G) Side Graphics into channel slides on both sides of display.

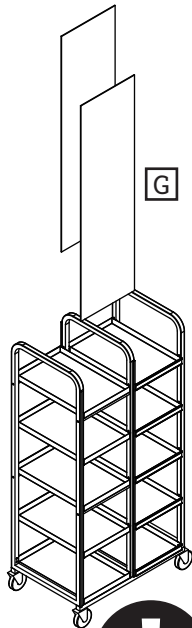

**11** Slide x10 (H) Channel Strips into the front of each (C) and (D) Shelf, ensuring that the corresponding brand is shown facing.

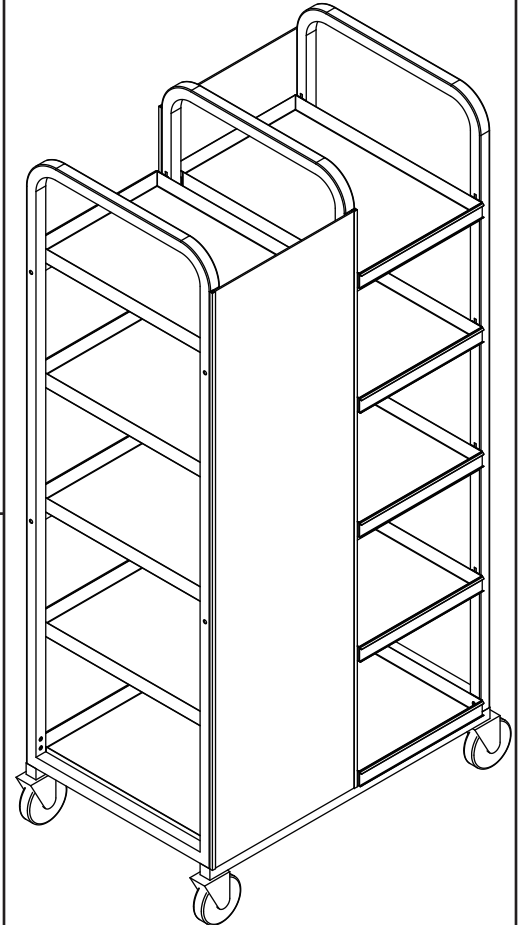
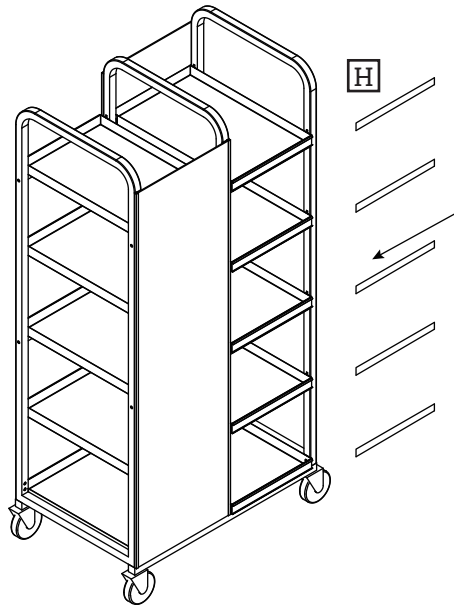

## MISSING PARTS / DAMAGE CLAIM INSTRUCTIONS

1. **DO NOT** discard the box or original packaging.  
In the case of damaged goods caused by shipping, photo evidence will be required.
2. Take photos of the box & markings.  
A photo of the markings (text) on the side of the box is required for all cases in which a replacement part is needed. This helps to identify the item number and ensures the correct parts are pulled.
3. Take photos of damage (if applicable).  
A photo of the damaged part(s) is always required to file a claim and expediently process the replacement part. Please make sure you keep the box even if it is damaged.
4. Send an email with the images requested.  
Email a description of the claim along with the images required above at [displaybuilds.com/contact](http://displaybuilds.com/contact) or directly to [help@displaybuilds.com](mailto:help@displaybuilds.com). Call our toll-free number 1-866-308-8368 for further assistance.