

KDP Dark Berry / Jurassic World Double-Sided Display - Assembly Instructions



Scan the QR code or visit the web address directly to view the **assembly video**: displaybuilds.com/instructions_18547



<p>A</p> <p>Body</p> <p>2</p>	<p>B</p> <p>Backer</p> <p>2</p>
<p>C</p> <p>Header</p> <p>1</p>	<p>D</p> <p>Shelf</p> <p>10</p>
<p>E</p> <p>Base Graphic</p> <p>2</p>	<p>F</p> <p>Foam Tape</p> <p>8</p>
<p>G</p> <p>Fastener</p> <p>12</p>	<p>H</p> <p>Support Bar</p> <p>10</p>

1 Lay (A) Body down with graphics facing the floor. Fold (B) Backer side tab as shown and align the holes with those in the (A) Body, closest to the front. Fold flap on (A) Body over the tab on the (B) Backer. Secure all panels with x2 (G) Fasteners, placing the head of the fastener on the graphic side.

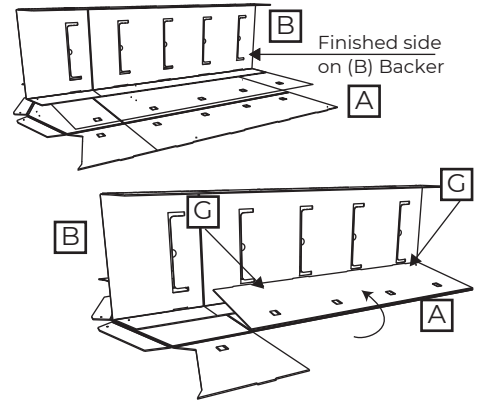

2 Remove backing on x1 (F) Foam Tape and place on the inside of the top tab on the (A) Body. Fold flap on side of (A) Body inward, and then fold over and stick the top tab down. Secure with x1 (G) Fastener.

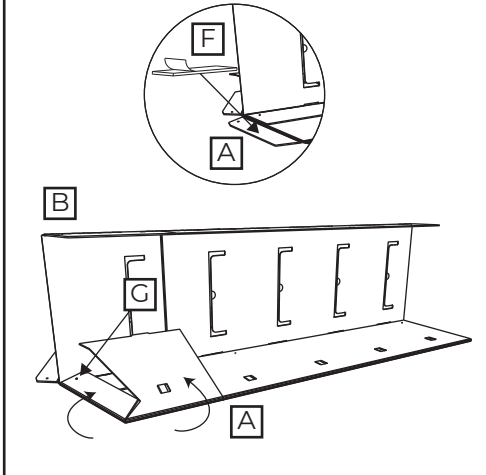

3 Place the other (B) Backer on the other side of the first and align holes in the (A) Body. Repeat the same steps as the first, folding the side flap on the (A) Body over the tab on the (B) Backer and securing with x2 (G) Fasteners, placing the head of the fastener on the graphic side.

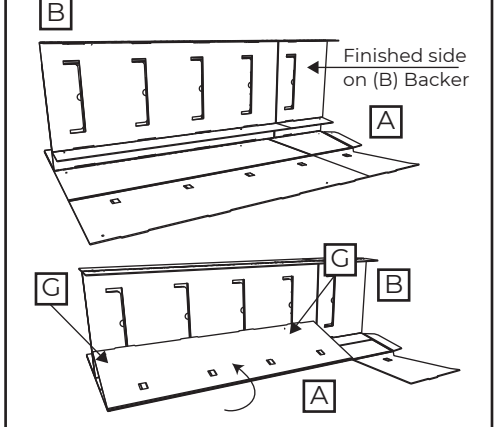

4 Remove backing on x1 (F) Foam Tape and place on the inside of the top tab on the (A) Body. Fold flap on side of (A) Body inward, and then fold over and stick the top tab down. Secure with x1 (G) Fastener.

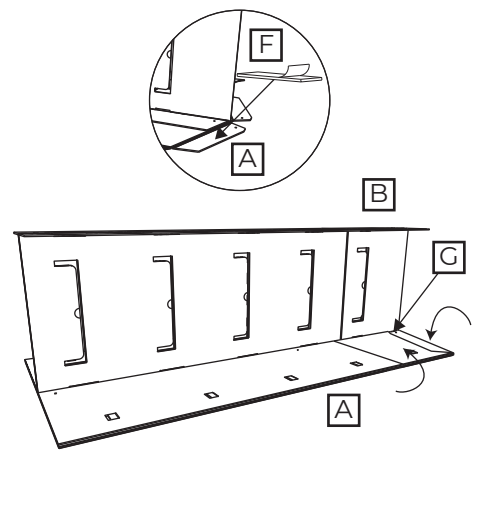

5 Stand display up and align the other (A) Body with the holes in the (B) Backers.

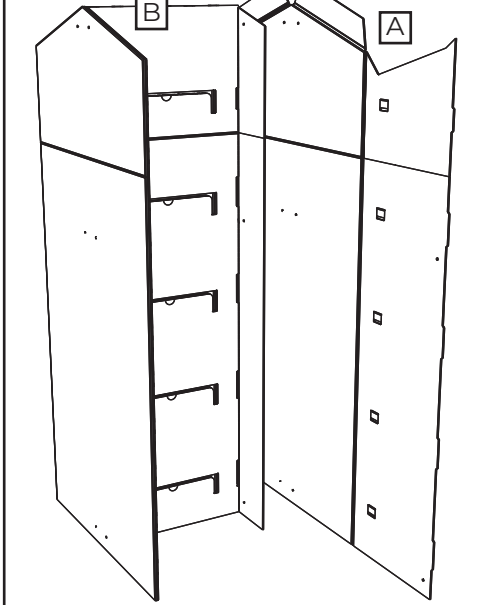

6 On both sides of the display, fold each bottom flap on (A) Body over the tab on the (B) Backer. Secure with x4 (G) Fasteners, placing the head of the fastener on the graphic side.

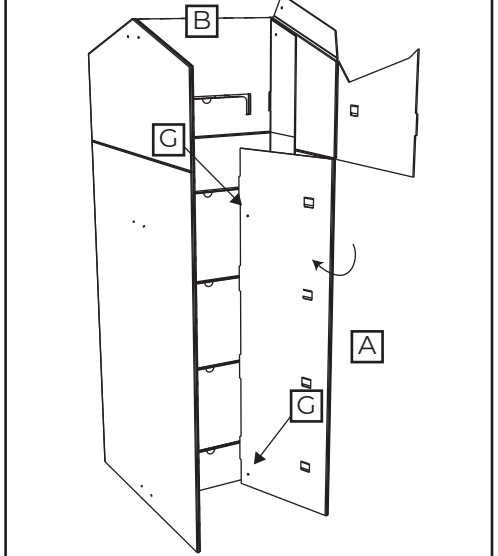

KDP Dark Berry / Jurassic World Double-Sided Display - Assembly Instructions

JOB 18547



Scan the QR code or visit the web address directly to view the **assembly video**: displaybuilds.com/instructions_18547



7 Remove backing on x2 (F) Foam Tape and place on the inside of each top tab on the (A) Body, on both front and back of the display. Fold flaps on top side of (A) Body inward, and then fold over and stick each top tab down. Secure with x2 (G) Fasteners.

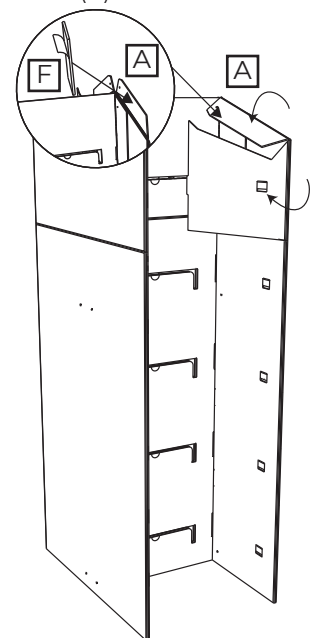

8 Install x10 (H) Support Bars by inserting into each slot on both sides of the (A) Body.

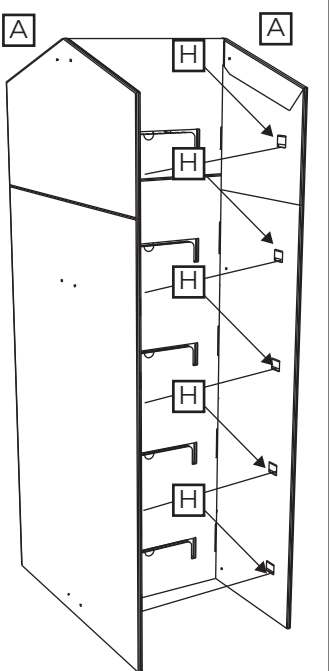

9 Remove backing on (F) Foam Tape and place on the side tab of each (E) Base Graphic. Secure into place at the bottom of each side of the display.

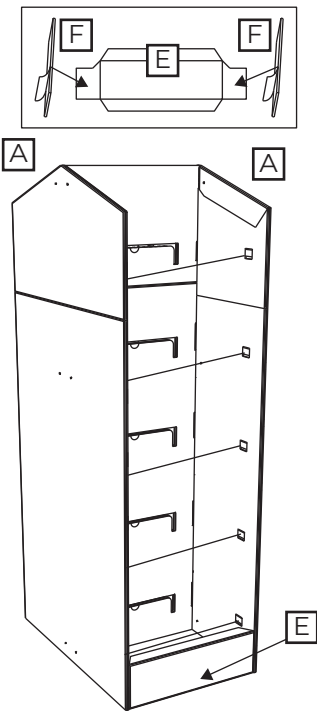

10 Assemble each of the ten (D) Shelves by folding as shown.

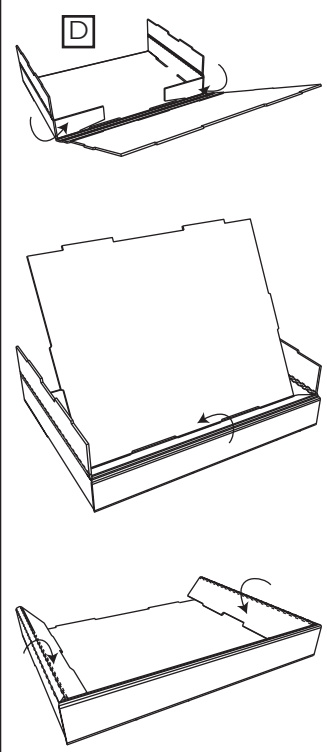

11 Pull flaps on the back of each (B) Backer forward - BUT DO NOT CREASE OR FOLD - fold down, and insert tab at the back of each assembled shelf to install. Rest the front of each shelf on the (H) Support Bar.

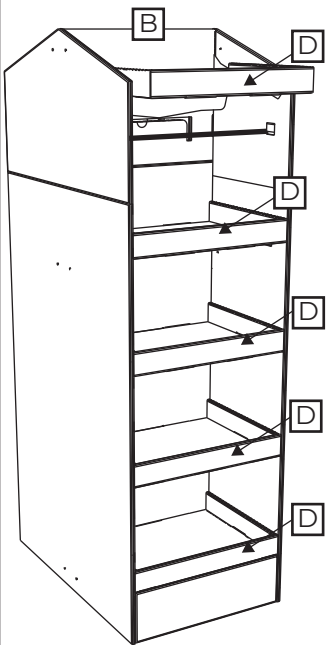

12 Insert (C) Header to complete assembly.

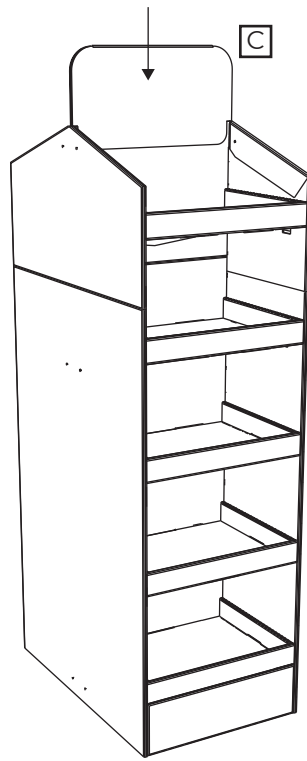

MISSING PARTS / DAMAGE CLAIM INSTRUCTIONS

- 1. DO NOT discard the box or original packaging.**
In the case of damaged goods caused by shipping, photo evidence will be required.
- 2. Take photos of the box & markings.**
A photo of the markings (text) on the side of the box is required for all cases in which a replacement part is needed. This helps to identify the item number and ensures the correct parts are pulled.
- 3. Take photos of damage (if applicable).**
A photo of the damaged part(s) is always required to file a claim and expediently process the replacement part. Please make sure you keep the box even if it is damaged.
- 4. Send an email with the images requested.**
Email a description of the claim along with the images required above at displaybuilds.com/contact or directly to help@displaybuilds.com. Call our toll-free number 1-866-308-8368 for further assistance.