



Sugarlands Shine Circle Wire Rack - Assembly Instructions

JOB 18529



Scan the QR code or visit the web address directly to view the assembly video: displaybuilds.com/instructions_18529

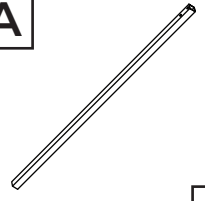
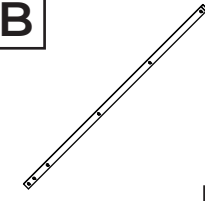
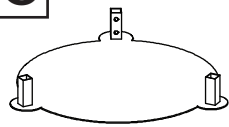
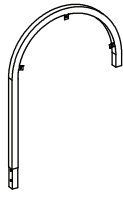
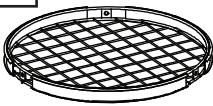
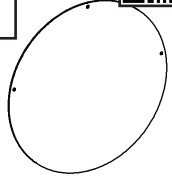
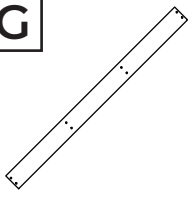
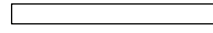

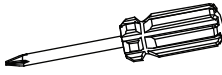
A  Header Leg 1	B  Leg 2	C  Base Frame 1	D  Header Frame 1	E  Shelf 4	F  Header Graphic 1
G  Base Graphic 1	H  Shelf Graphic 12	I  Push Clip 3	J  Bolt (M6 x 12) 20	K  Tool 1	

1 Insert (A) Header Leg and (B) Legs into (C) Base Frame. Note the side with 6 holes should face the inside of the display.

2 Round out (G) Base Graphic as shown and secure to (A) Header Leg and both (B) Legs with x2 (J) Bolts each. Tighten with (K) Tool.

3 Install each (E) Shelf by fastening to corresponding holes in (A) Header Leg and (B) Legs with x3 (J) Bolts each and tighten with (K) Tool.

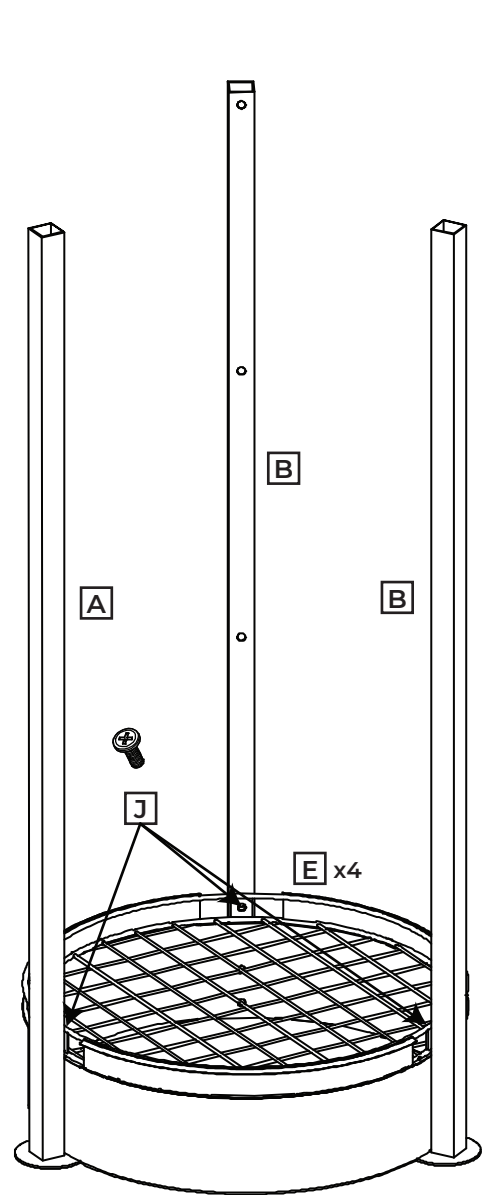
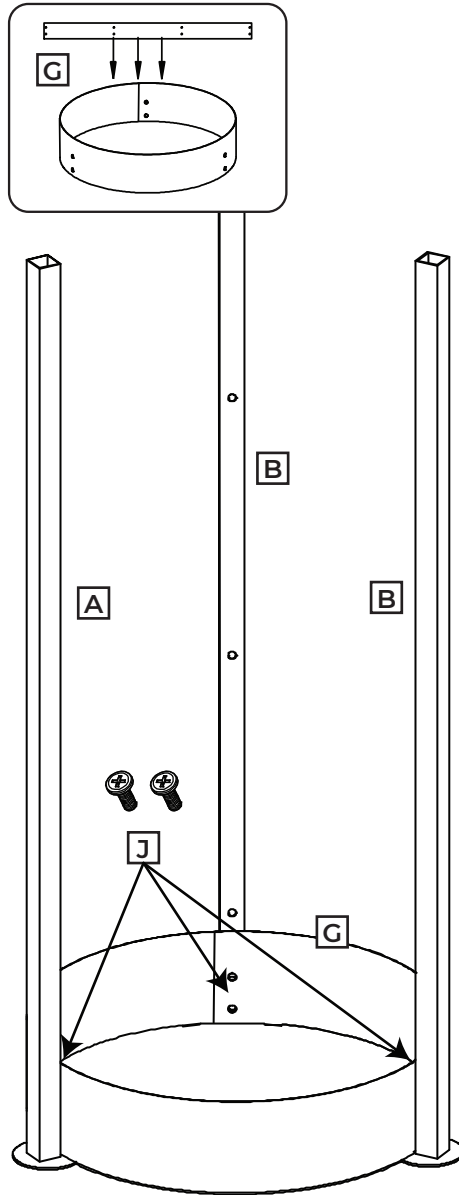
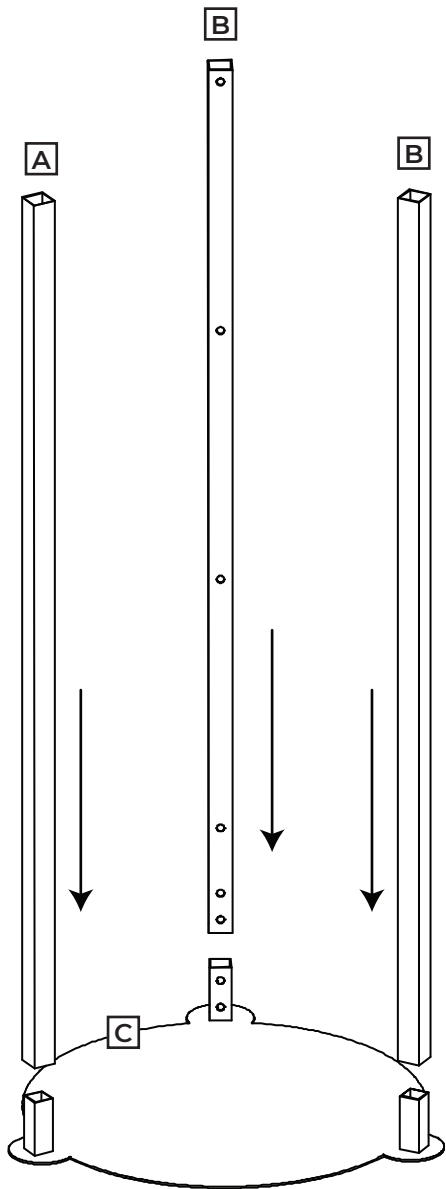

Sugarlands Shine Circle Wire Rack - Assembly Instructions

JOB 18529



Scan the QR code or visit the web address directly to view the assembly video: displaybuilds.com/instructions_18529



- 4** Insert (D) Header Frame into (A) Header Leg and secure with x2 (J) Bolts; tighten with (K) Tool.

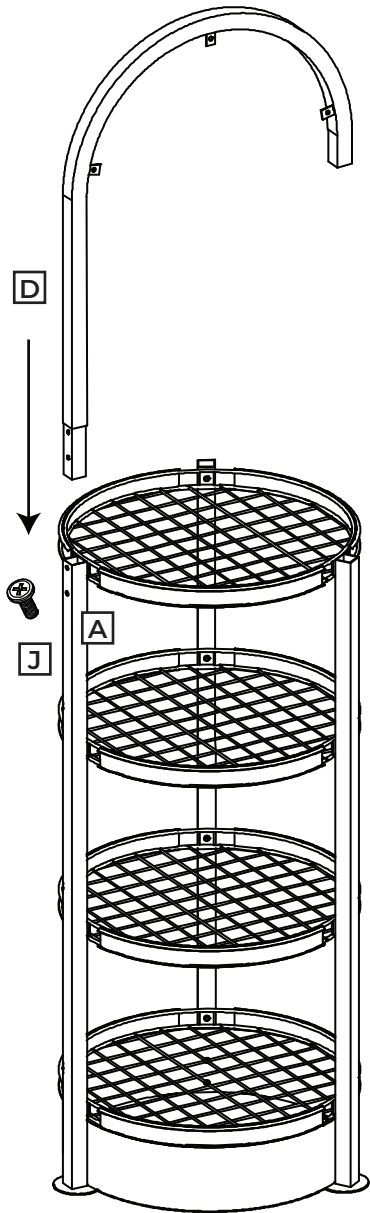

- 5** Attach (F) Header Graphic to (D) Header Frame with x3 (I) Push Clips. Slide x3 (H) Shelf Graphics into the slides on each (E) Shelf as shown below.

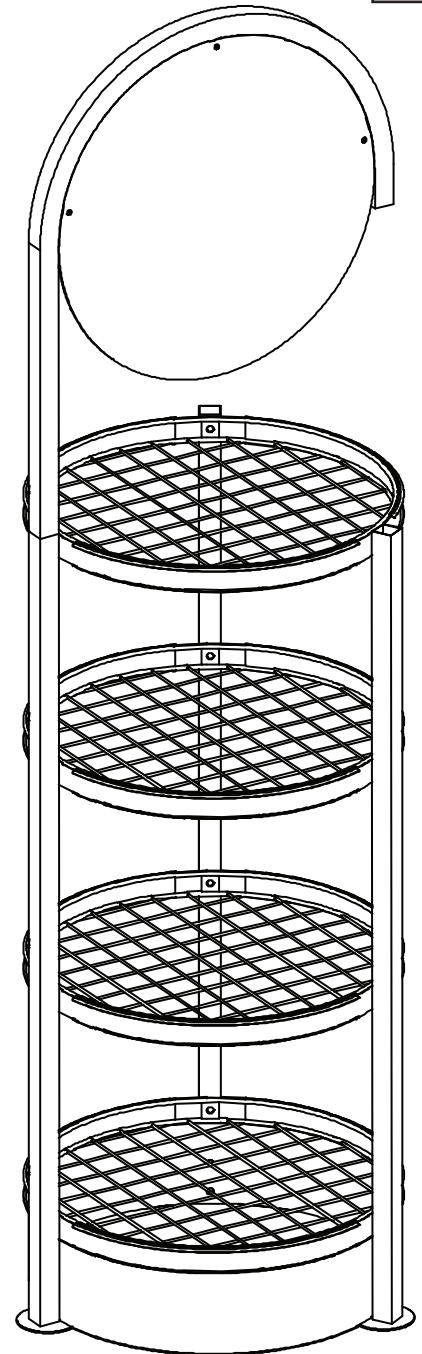
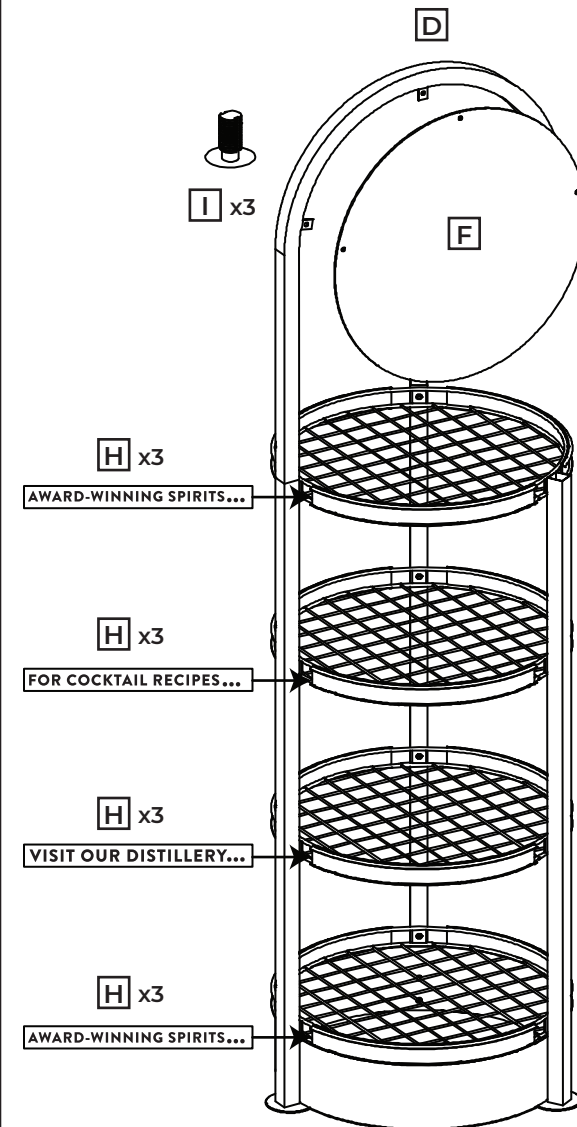

MISSING PARTS / DAMAGE CLAIM INSTRUCTIONS

1. **DO NOT** discard the box or original packaging.

In the case of damaged goods caused by shipping, photo evidence will be required.

2. Take photos of the box & markings.

A photo of the markings (text) on the side of the box is required for all cases in which a replacement part is needed. This helps to identify the item number and ensures the correct parts are pulled.

3. Take photos of damage (if applicable).

A photo of the damaged part(s) is always required to file a claim and expediently process the replacement part. Please make sure you keep the box even if it is damaged.

4. Send an email with the images requested.

Email a description of the claim along with the images required above at displaybuilds.com/contact or directly to help@displaybuilds.com. Call our toll-free number 1-866-308-8368 for further assistance.