

Kingsford 2022 Small Rolling Rack - Assembly Instructions

JOB 18567

Scan the QR code or visit the web address directly to view the assembly video: displaybuilds.com/instructions_18567

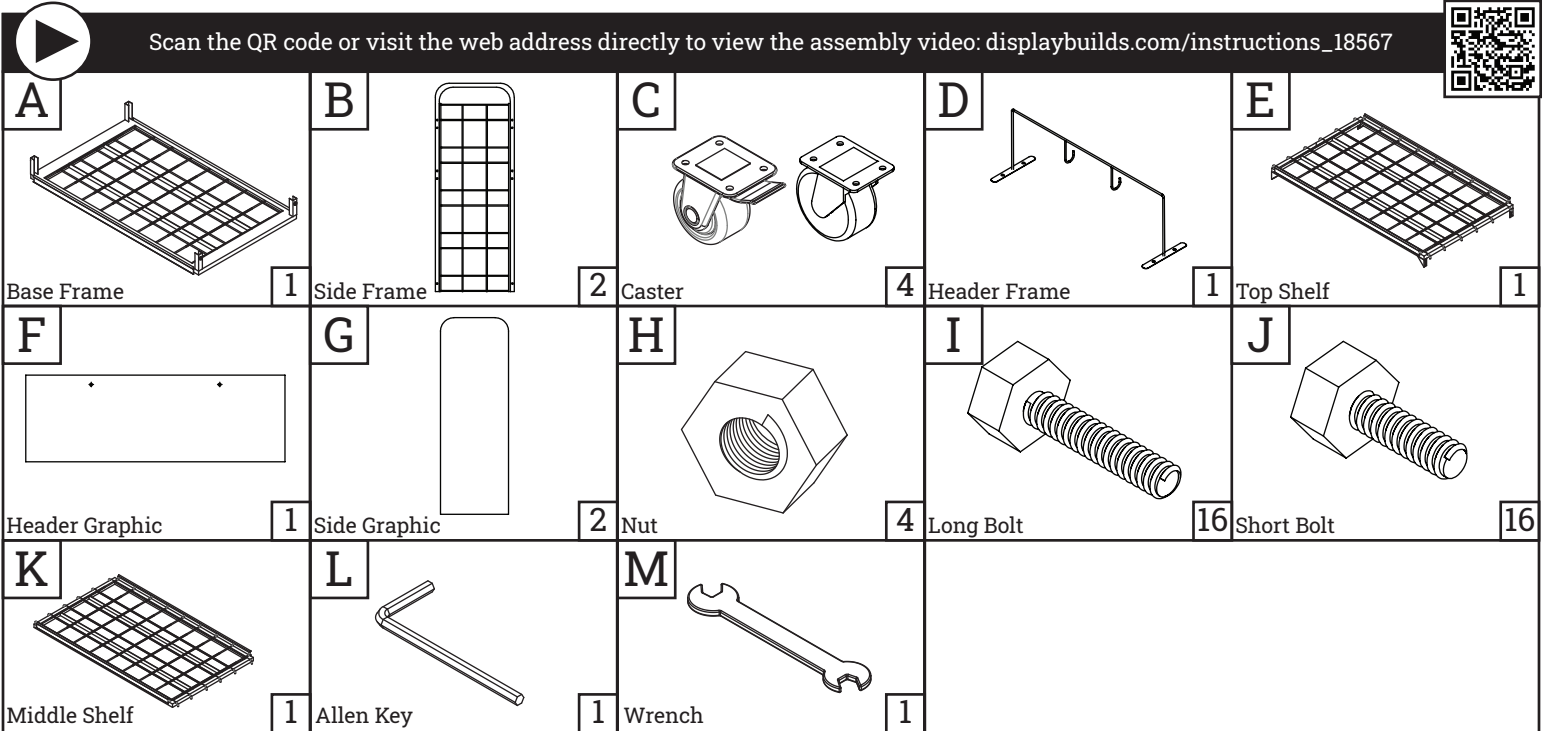

1 Attach each (B) Side Frame to the (A) Base Frame using x4 (I) Long Bolts on each side. Tighten with tool.

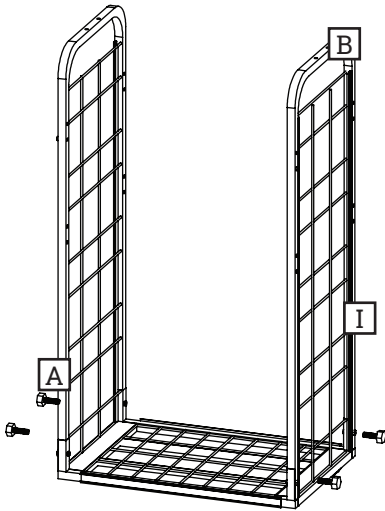

2 Attach each (C) Caster to the (A) Base Frame using x1 (I) Long Bolt and x3 (J) Short Bolts on each as shown below. Tighten with tool.

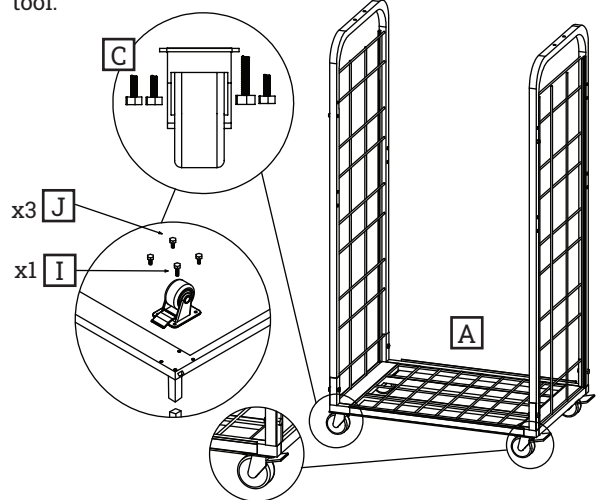

3 Hang (K) Middle Shelf on the (B) Side Frames at desired height.

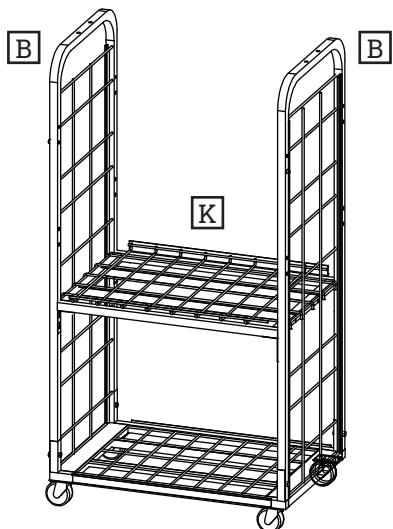

4 Hang top (E) Shelf and secure with x8 (I) Long Bolts and x4 (H) Nuts. Tighten with tool.

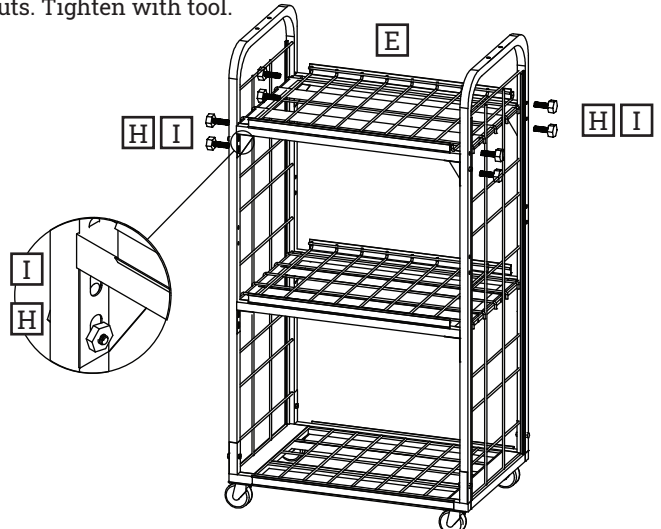



Scan the QR code or visit the web address directly to view the assembly video: displaybuilds.com/instructions_18567



- 5** Insert (D) Header Frame into (B) Side Frames and secure with x4 (J) Short Bolts. Tighten with tool.

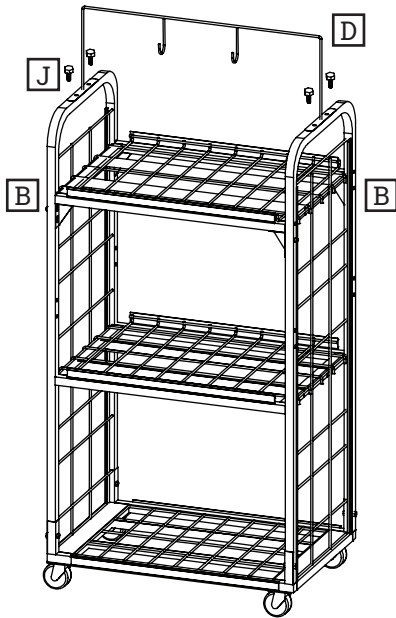

- 6** Slide (G) Side Graphics into channel slides on (B) Side Frames and hang (F) Header Graphic from hooks on (D) Header Frame.

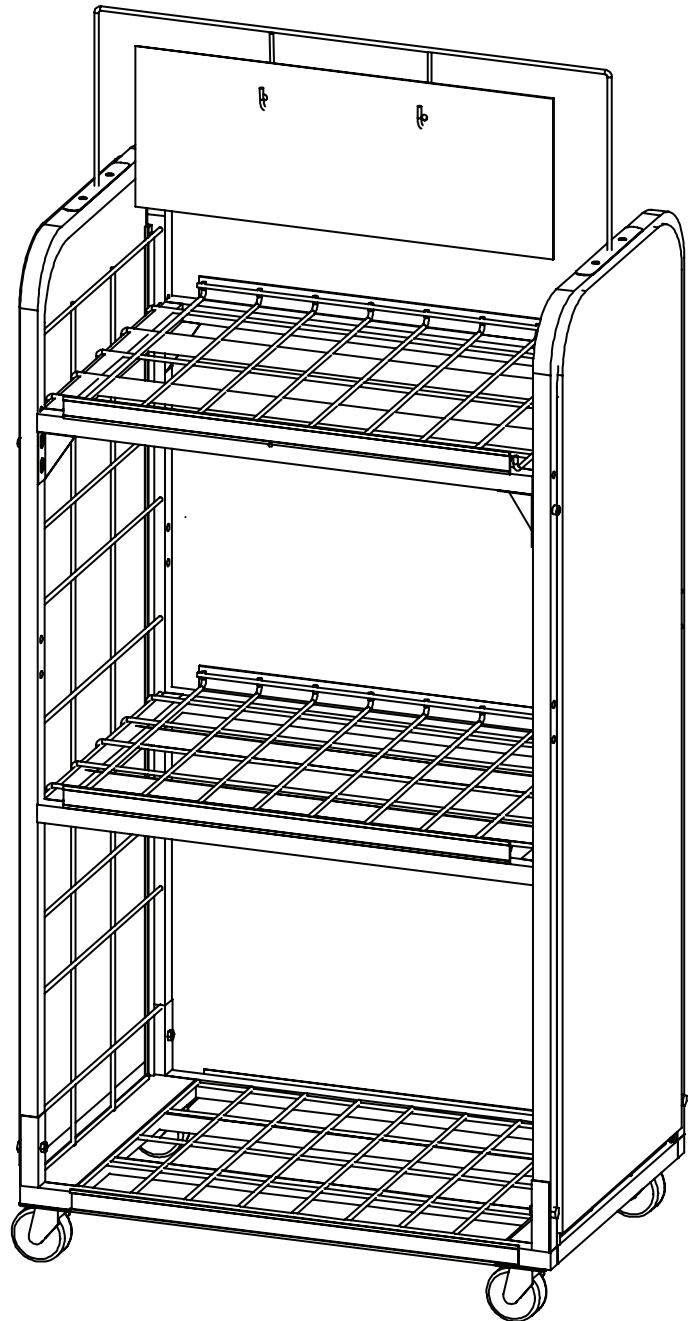
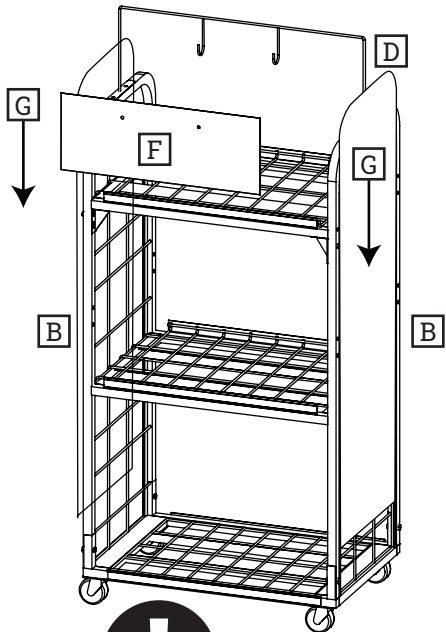

MISSING PARTS / DAMAGE CLAIM INSTRUCTIONS

1. **DO NOT** discard the box or original packaging.
In the case of damaged goods caused by shipping, photo evidence will be required.
2. Take photos of the box & markings.
A photo of the markings (text) on the side of the box is required for all cases in which a replacement part is needed. This helps to identify the item number and ensures the correct parts are pulled.
3. Take photos of damage (if applicable).
A photo of the damaged part(s) is always required to file a claim and expediently process the replacement part. Please make sure you keep the box even if it is damaged.
4. Send an email with the images requested.
Email a description of the claim along with the images required above at displaybuilds.com/contact or directly to help@displaybuilds.com. Call our toll-free number 1-866-308-8368 for further assistance.