

Aspire Rack - Assembly Instructions

JOB 18620

Scan the QR code or visit the web address directly to view the assembly video: displaybuilds.com/instructions_18620

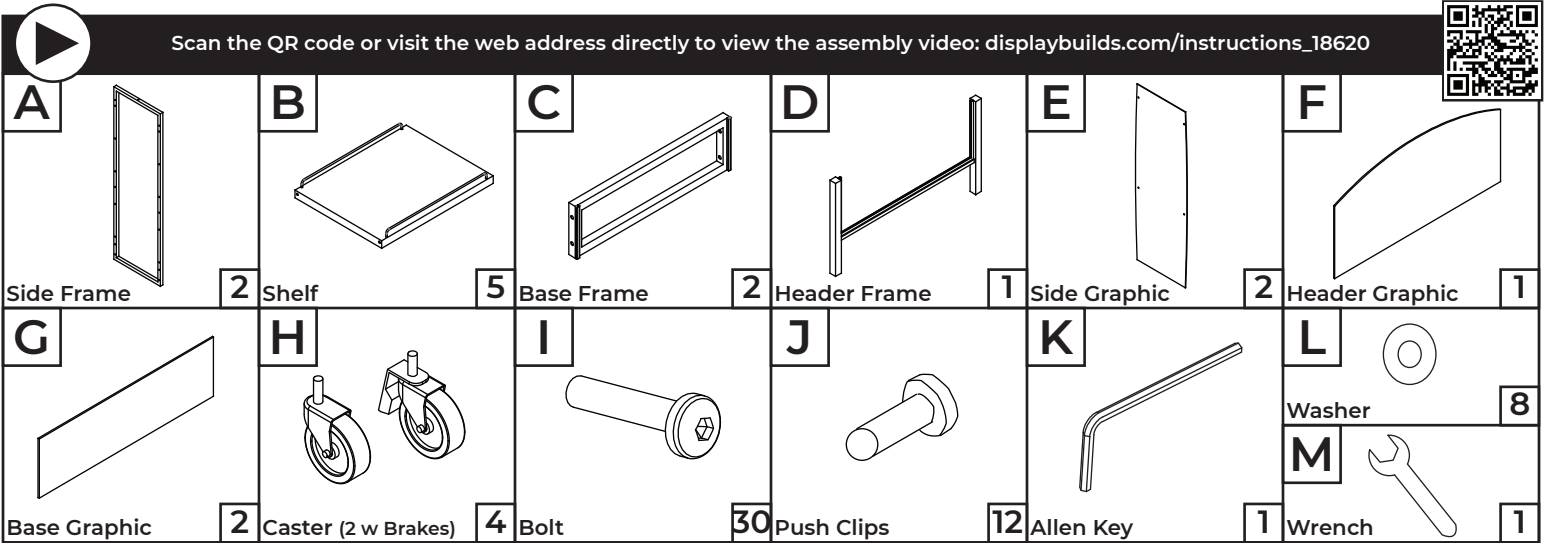

1 Install (H) Casters by threading x2 Locking into one (C) Base Frame and x2 Non-Locking into the other (C) Base Frame. Tighten with (M) Wrench. (Do NOT install (H) Casters into (A) Side Frames.)

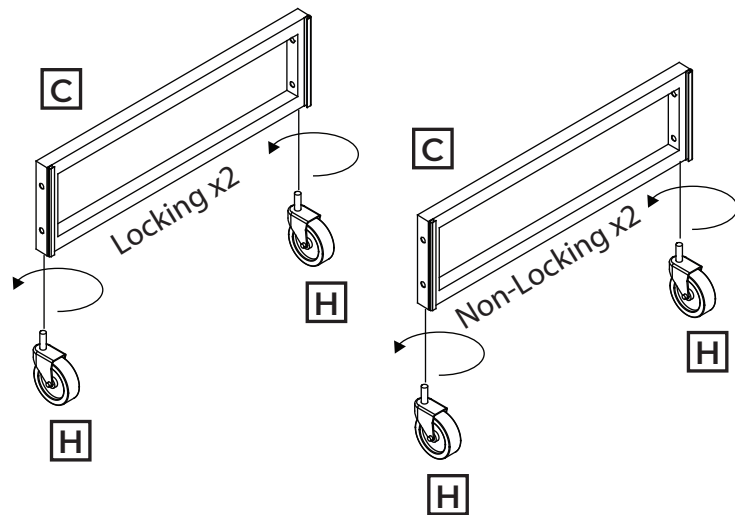

2 On a soft surface to prevent scratching, attach each (C) Base Frame with (H) Casters to each (A) Side Frame with x8 (I) Bolts and (L) Washers. Attach (D) Header Frame to (A) Side Frames with x2 (I) Bolts. Tighten all (I) Bolts with (K) Allen Key.

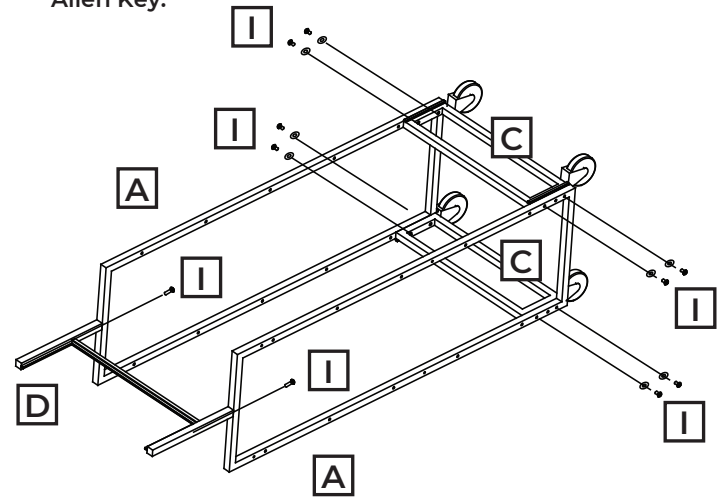

3 Stand display up, attach each (B) Shelf to (A) Side Frames with x20 (I) Bolts, then tighten all with (K) Allen Key.

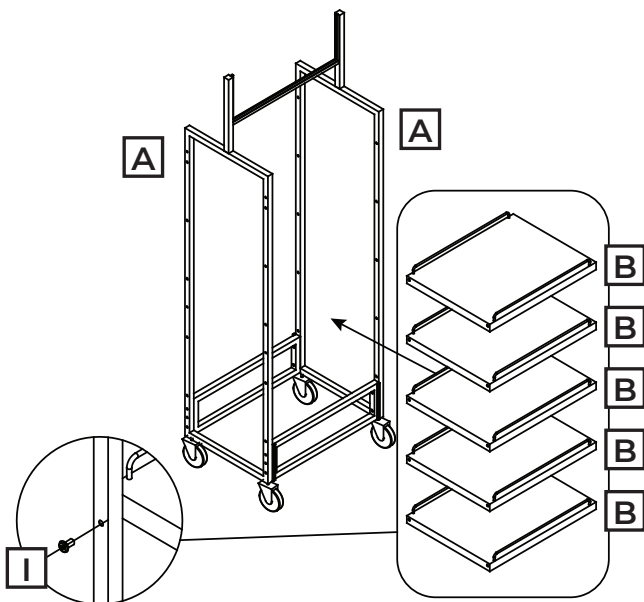

4 Attach (E) Side Graphics to (A) Side Frames with x12 (J) Push Clips.

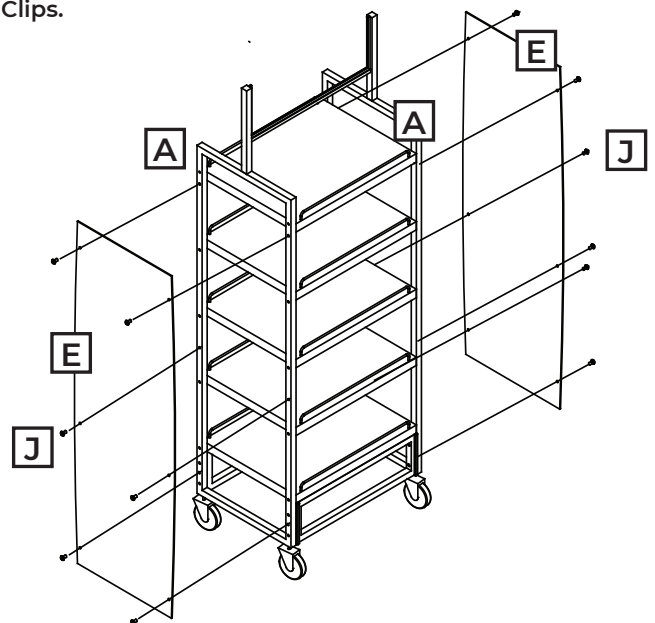



Scan the QR code or visit the web address directly to view the assembly video: displaybuilds.com/instructions_18620



5 Install (F) Header Graphic and (G) Base Graphics by sliding each into the corresponding channel slides.

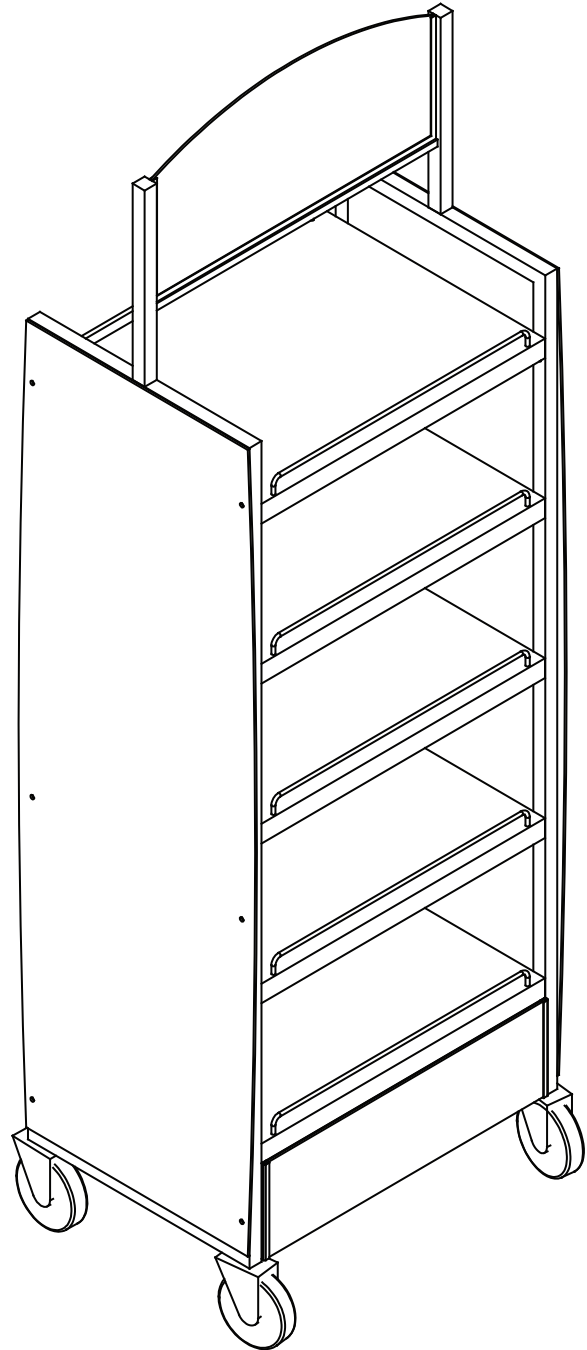
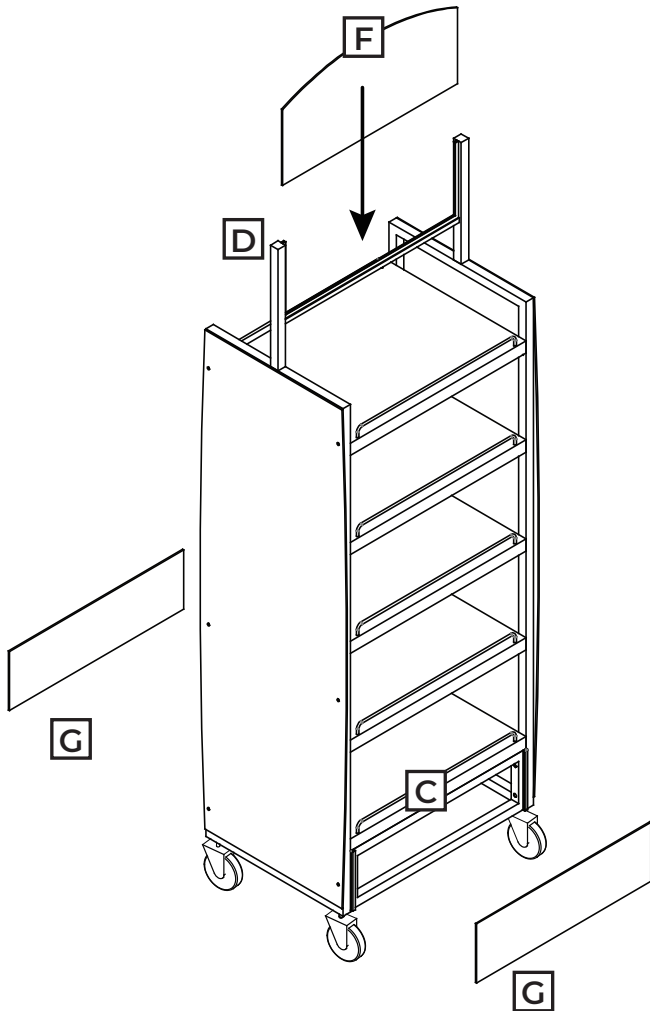

MISSING PARTS / DAMAGE CLAIM INSTRUCTIONS

1. **DO NOT** discard the box or original packaging.

In the case of damaged goods caused by shipping, photo evidence will be required.

2. Take photos of the box & markings.

A photo of the markings (text) on the side of the box is required for all cases in which a replacement part is needed. This helps to identify the item number and ensures the correct parts are pulled.

3. Take photos of damage (if applicable).

A photo of the damaged part(s) is always required to file a claim and expediently process the replacement part. Please make sure you keep the box even if it is damaged.

4. Send an email with the images requested.

Email a description of the claim along with the images required above at displaybuilds.com/contact or directly to help@displaybuilds.com. Call our toll-free number 1-866-308-8368 for further assistance.