

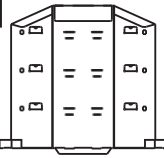

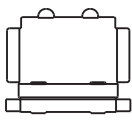



Aspire 4-Shelf Display - Assembly Instructions

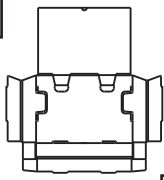
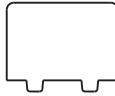

Scan the QR code or visit the web address directly to view the assembly video: displaybuilds.com/instructions_18921

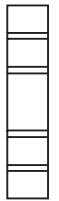

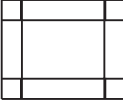
<p>A</p>  <p>Tower</p>	<p>B</p>  <p>Bottom Shelf</p>	<p>C</p>  <p>Bottom Shelf Pad</p>	<p>D</p>  <p>Shelf</p>	<p>E</p>  <p>Header</p>	<p>F</p>  <p>Support Bar</p>
<p>G</p>  <p>Shelf Filler</p>	<p>H</p>  <p>Shroud</p>	<p>I</p>  <p>Bottom Tray</p>			

1 Assemble all (D) Shelves by folding as shown.

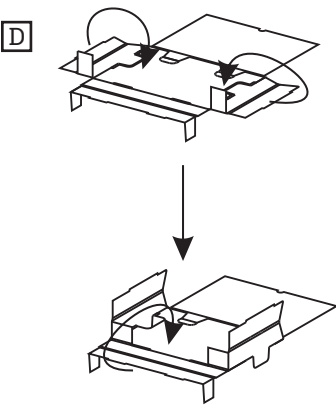

2 Assemble all (D) Shelves by folding as shown.

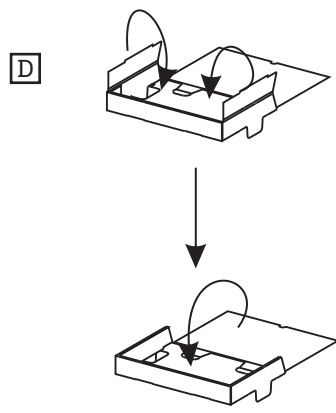

3 Hold the (A) Tower straight.

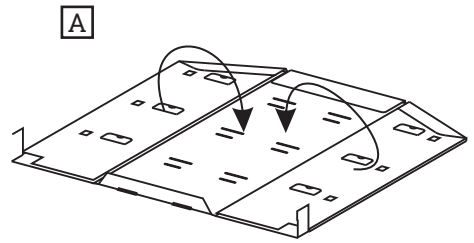

4 Insert the (B) Bottom Shelf side tabs to the (A) Tower side panel bottom holes as shown below.

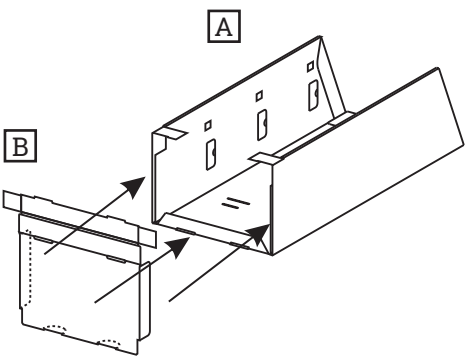

5 Hold the (A) Tower straight again after the (B) Bottom Shelf tabs all insert relative holes.

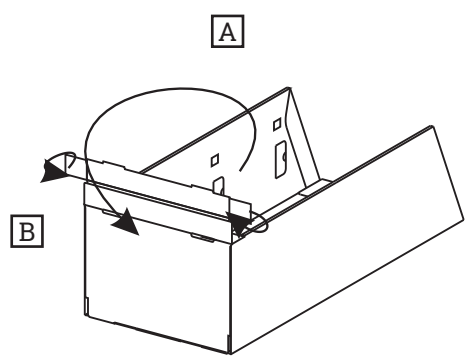

6 Put the side panel bottom tabs flat and then fold the (B) Bottom Shelf lip down to cover the tabs well.

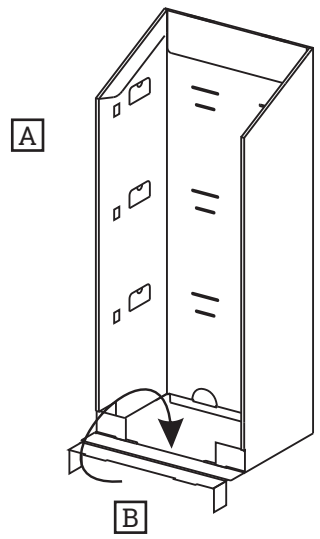



Scan the QR code or visit the web address directly to view the assembly video: displaybuilds.com/instructions_18921



7 Insert the (C) Bottom Shelf Pad into the Bottom Shelf.

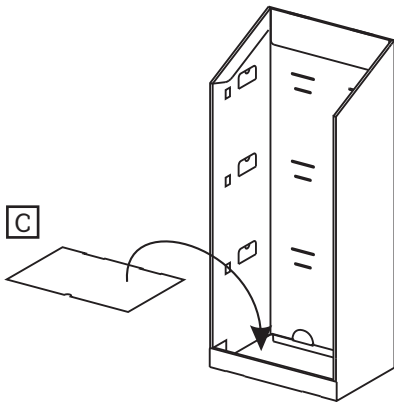

8 Insert the (F) Support Bar to the side panel holes as shown below.

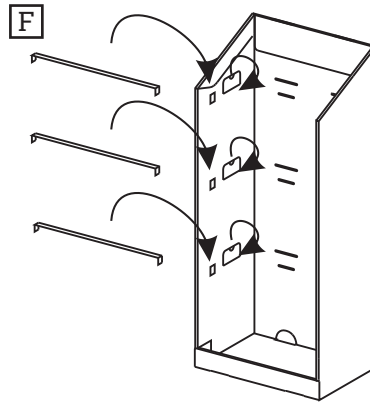

9 Put the assembled (D) Shelves tabs to the back panel holes accordingly. Also, insert the Shelf side tabs to the side panel holes as well.

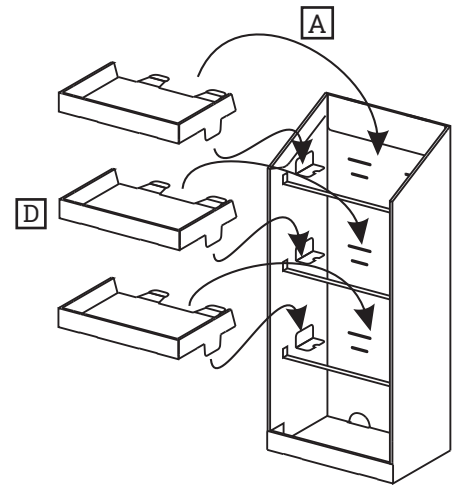

10 Fold the tabs down through the holes to the front.

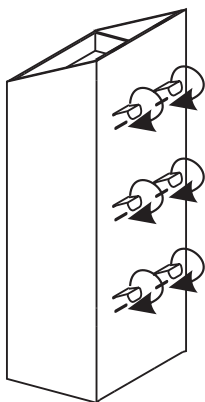

11 Insert the Header into the back panel top holes.

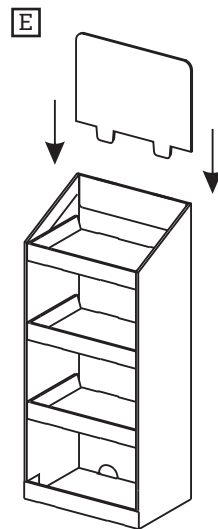

12 Display is ready.

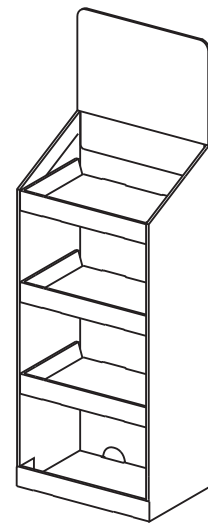

Aspire 4-Shelf Display - Assembly Instructions



Scan the QR code or visit the web address directly to view the assembly video: displaybuilds.com/instructions_18921



13 Fold the (G) Shelf Fillers like shown below and put them into the Shelves.

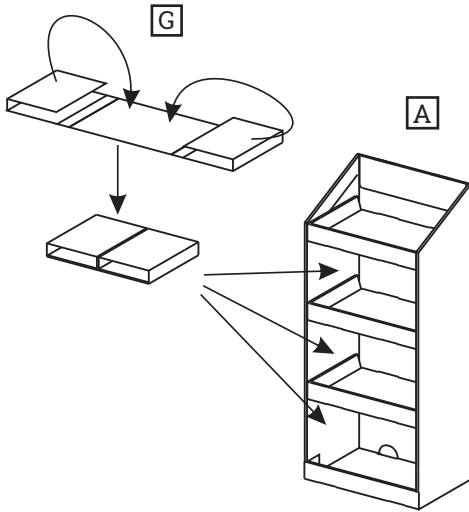

14 Put the (I) Bottom Tray to the (A) Tower bottom and put the (E) Header to the back of the Display.

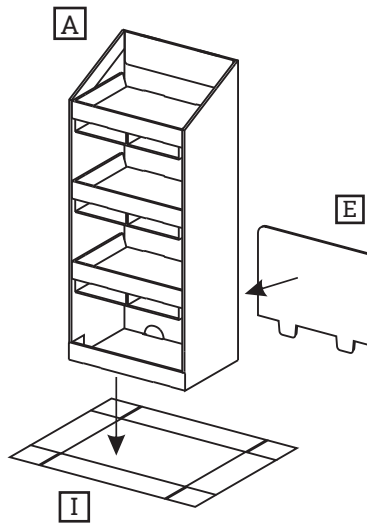

15 Hold the (H) Shroud straight and then cover the Display from top to bottom.

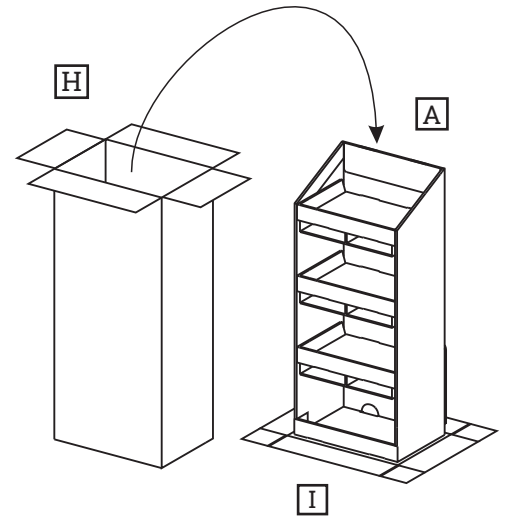

16 Fold the (H) Shroud tabs together like shown below and use tape to bend it.

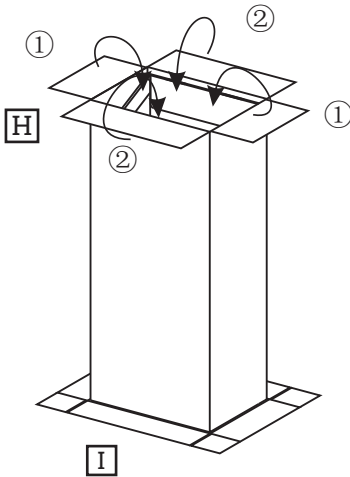

17 Fold the (I) Bottom Tray like shown below and use tape to bend it.

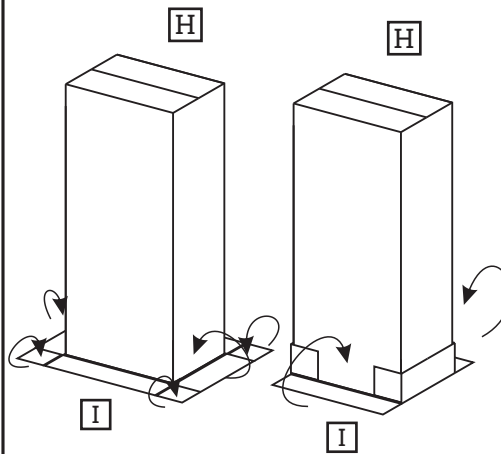

18 Assembled.

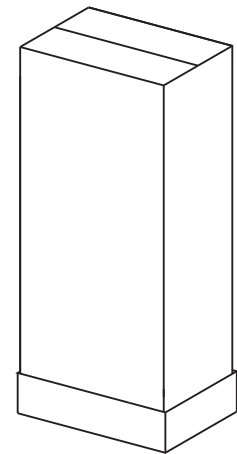

MISSING PARTS / DAMAGE CLAIM INSTRUCTIONS

1. **DO NOT** discard the box or original packaging.
In the case of damaged goods caused by shipping, photo evidence will be required.
2. Take photos of the box & markings.
A photo of the markings (text) on the side of the box is required for all cases in which a replacement part is needed. This helps to identify the item number and ensures the correct parts are pulled.
3. Take photos of damage (if applicable).
A photo of the damaged part(s) is always required to file a claim and expediently process the replacement part. Please make sure you keep the box even if it is damaged.
4. Send an email with the images requested.
Email a description of the claim along with the images required above at displaybuilds.com/contact or directly to help@displaybuilds.com. Call our toll-free number 1-866-308-8368 for further assistance.