

# P&G Display - Assembly Instructions

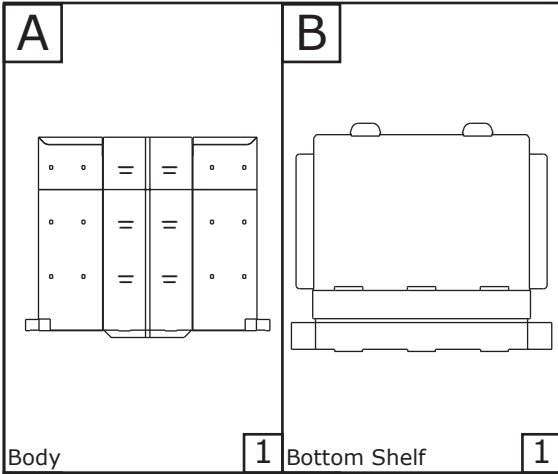

Scan the QR code or visit the web address directly to view the assembly video: [displaybuilds.com/instructions\\_19067](http://displaybuilds.com/instructions_19067)



Body 1 Bottom Shelf 1

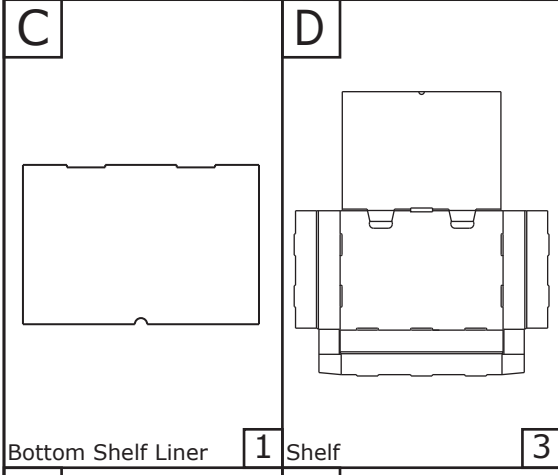

Bottom Shelf Liner 1 Shelf 3

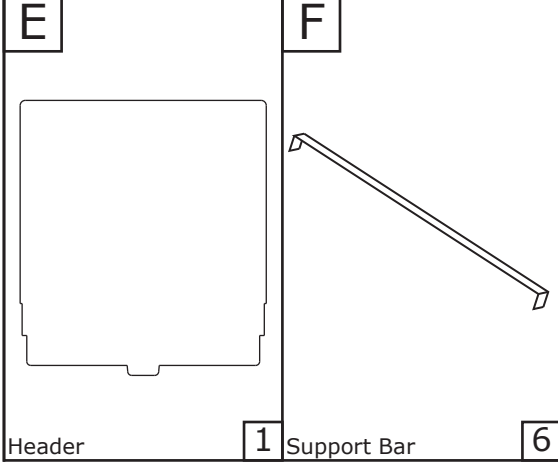

Header 1 Support Bar 6

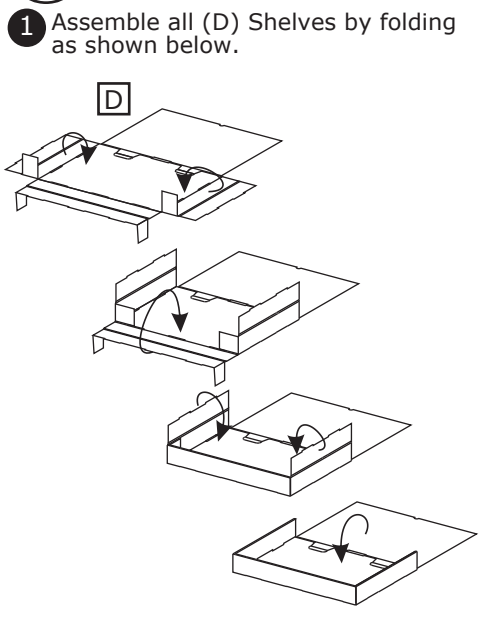

1 Assemble all (D) Shelves by folding as shown below.

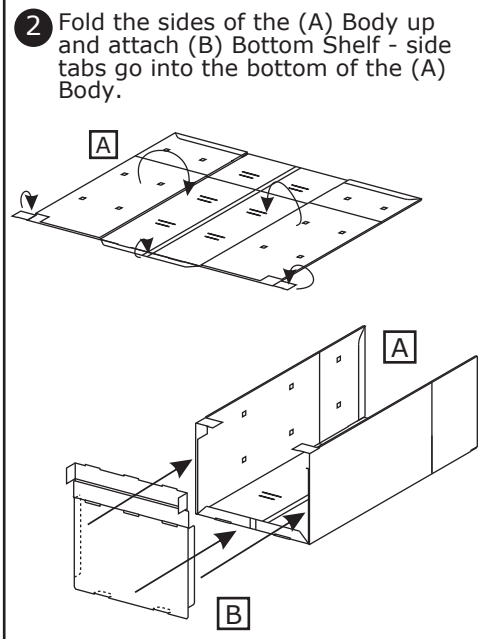

2 Fold the sides of the (A) Body up and attach (B) Bottom Shelf - side tabs go into the bottom of the (A) Body.

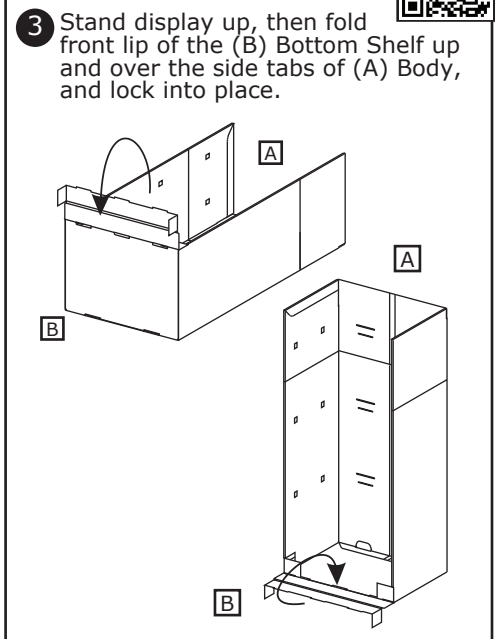

3 Stand display up, then fold front lip of the (B) Bottom Shelf up and over the side tabs of (A) Body, and lock into place.

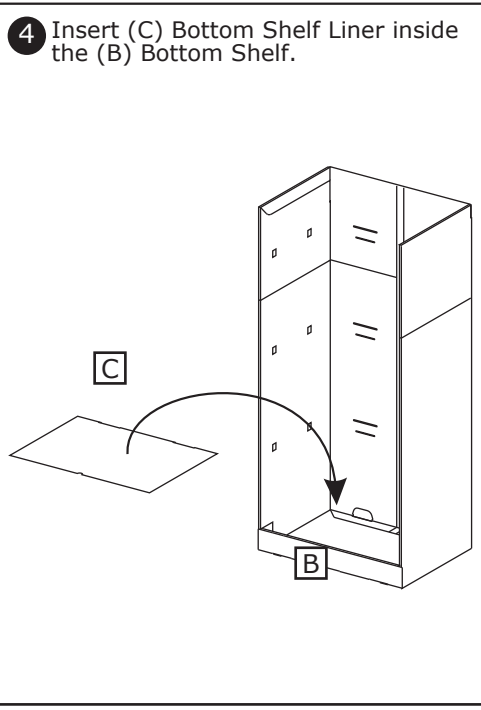

4 Insert (C) Bottom Shelf Liner inside the (B) Bottom Shelf.

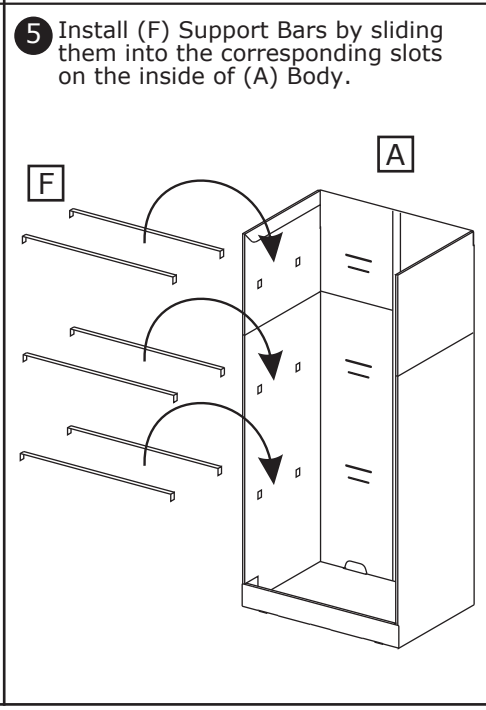

5 Install (F) Support Bars by sliding them into the corresponding slots on the inside of (A) Body.

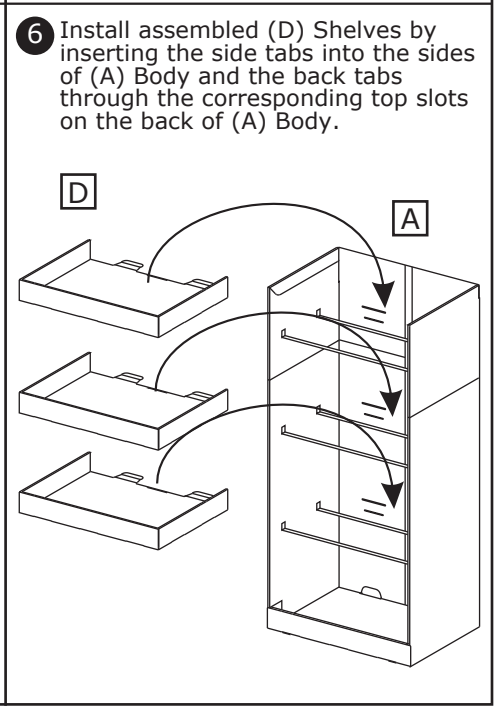

6 Install assembled (D) Shelves by inserting the side tabs into the sides of (A) Body and the back tabs through the corresponding top slots on the back of (A) Body.



Scan the QR code or visit the web address directly to view the assembly video: [displaybuilds.com/instructions\\_19067](http://displaybuilds.com/instructions_19067)



**7** On the back of the display, fold the tabs of each (D) Shelf down and insert them back into the corresponding bottom slots on the (A) Body to lock into place.

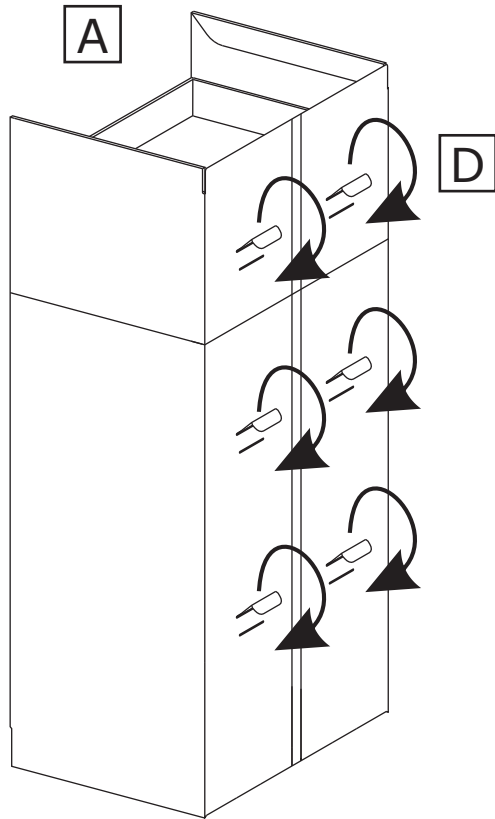

**8** Insert (E) Header into (A) Body to complete display's assembly.

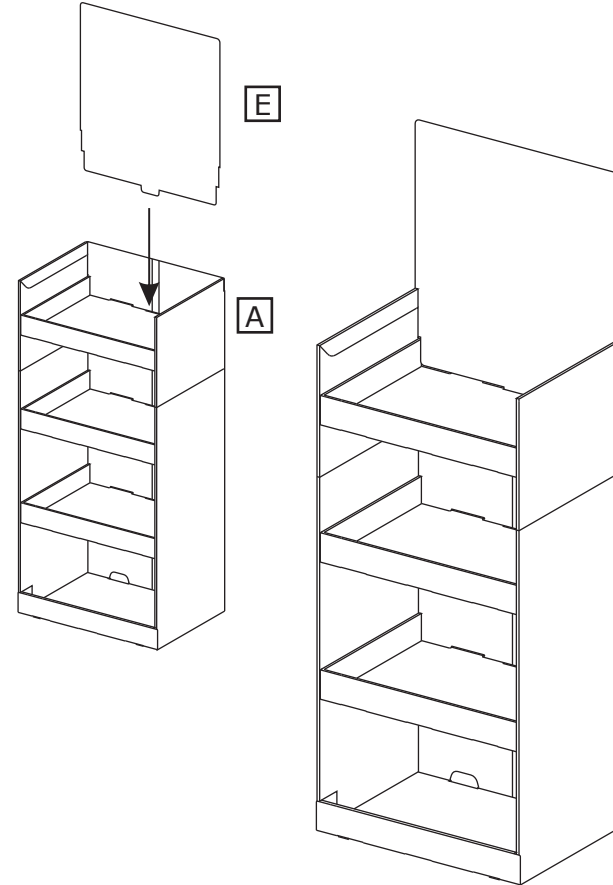

## MISSING PARTS / DAMAGE CLAIM INSTRUCTIONS

1. DO NOT discard the box or original packaging.

In the case of damaged goods caused by shipping, photo evidence will be required.

2. Take photos of the box & markings.

A photo of the markings (text) on the side of the box is required for all cases in which a replacement part is needed. This helps to identify the item number and ensures the correct parts are pulled.

3. Take photos of damage (if applicable).

A photo of the damaged part(s) is always required to file a claim and expediently process the replacement part. Please make sure you keep the box even if it is damaged.

4. Send an email with the images requested.

Email a description of the claim along with the images required above at [displaybuilds.com/contact](http://displaybuilds.com/contact) or directly to [help@displaybuilds.com](mailto:help@displaybuilds.com). Call our toll-free number 1-866-308-8368 for further assistance.