

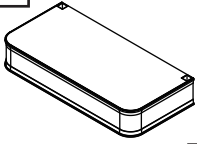

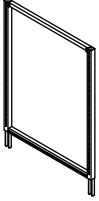

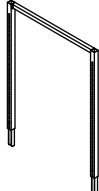

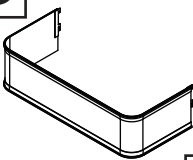

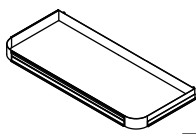

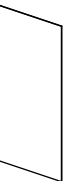

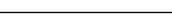
Coca-Cola / Circle K Cooler End Cap - Assembly Instructions

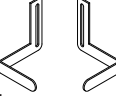
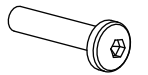
JOB 19176

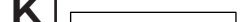
Scan the QR code or visit the web address directly to view the assembly video: displaybuilds.com/instructions_19176

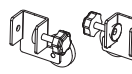

| | | | | | |
|---------------------------------------------------------------------------------------------------------------|----------------------------------------------------------------------------------------------------------------------|---------------------------------------------------------------------------------------------------------------|------------------------------------------------------------------------------------------------------------------|---------------------------------------------------------------------------------------------------------------------|----------------------------------------------------------------------------------------------------------------|
| A  Base 1 | B  Bottom Frame 1 | C  Top Frame 1 | D  Header Frame 1 | E  Shelf 4 | F  Bracket 2 |
| G  Back Panel 2 | H  Shelf POS - Side 8 | J  Header POS 1 | L  Cap Nut 2 | N  Z Bracket 2 | P  Bolt 12 |
| | I  Shelf POS - Front 4 | K  Base POS 1 | M  Magnet 2 | O  Magnet Bracket 2 | Q  Allen Key 1 |

1 Insert (B) Bottom Frame into (A) Base, attach x2 (N) Z Brackets to (A) Base, and secure using x4 (P) Bolts. Tighten with (Q) Allen Key.

Attention: (N) Z Brackets should be face-to-face (their position could be adjusted to match the cooler).

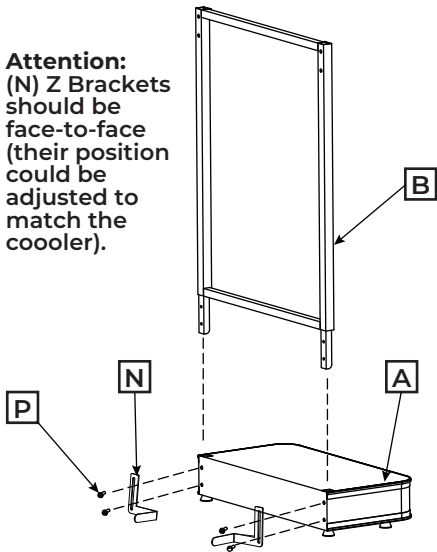

2 Insert (C) Top Frame into (B) Bottom Frame and secure using x4 (P) Bolts. Tighten with (Q) Allen Key.

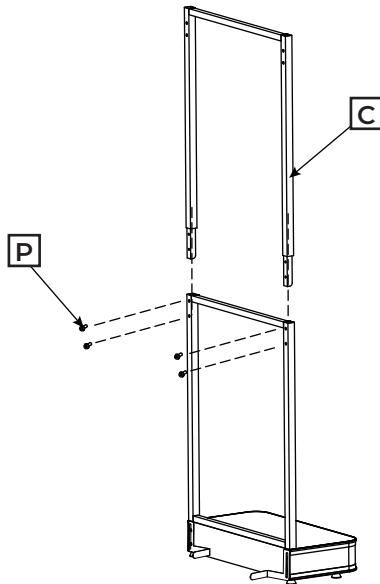

3 Insert x2 (G) Back Panels into channel slides on (B/C) Back Frame and slide all the way down.

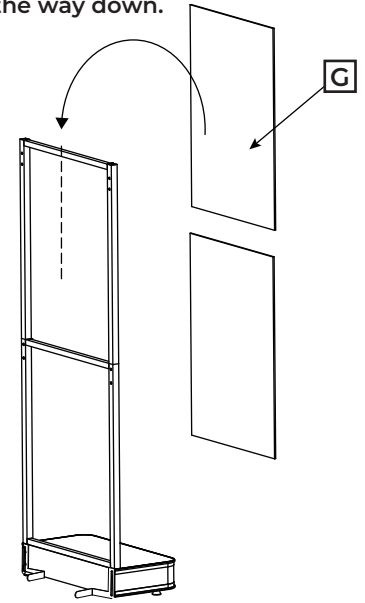

4 Install x4 (E) Shelves at height positions as required for product fitment.

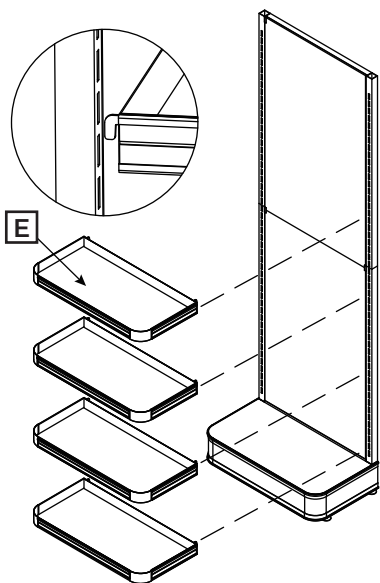

5 Hook (D) Header Frame onto (C) Top Frame as shown.

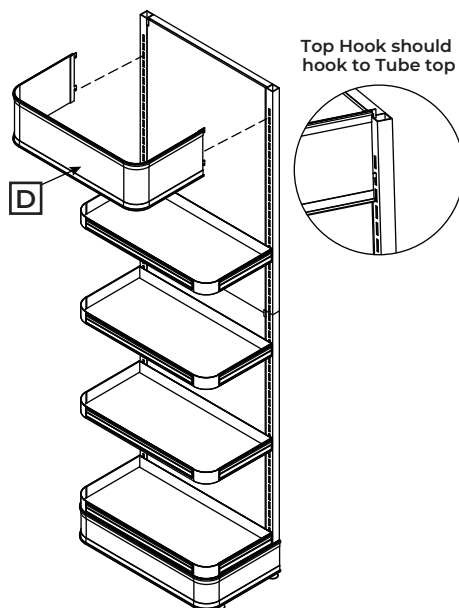

6 Insert the all POS panels by sliding into the corresponding channel slides: (J) Header POS into (D) Header Frame (H) Shelf POS - Side into (E) Shelf Side (I) Shelf POS Front into (E) Shelf Front (K) Base POS into (A) Base.

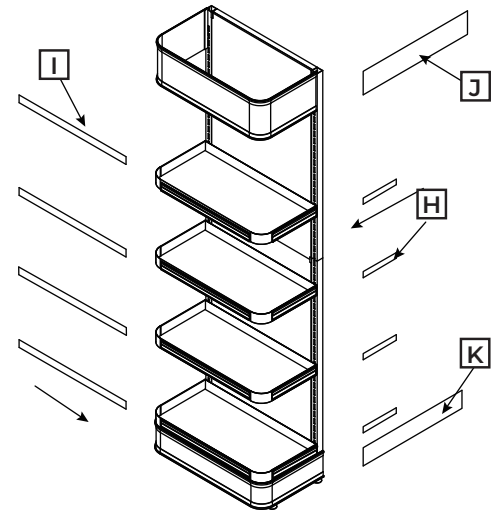

Coca-Cola / Circle K Cooler End Cap - Assembly Instructions

JOB 19176



Scan the QR code or visit the web address directly to view the assembly video: displaybuilds.com/instructions_19176



7 Attach x2 (F) Brackets to the (C) Top Frame with x4 (P) Bolts as shown; then tighten with (Q) Allen Key. Attach x2 (O) Magnet Brackets onto the Frame (leave in flexible position), and fix it to the Frame by tightening the thumb screw.

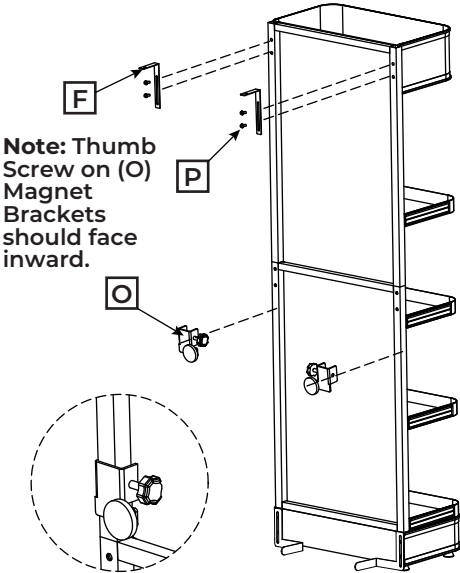

8 Insert x2 (M) Magnets into the x2 (F) Brackets with (M) Magnet facing down. Secure with x2 (L) Cap Nuts.

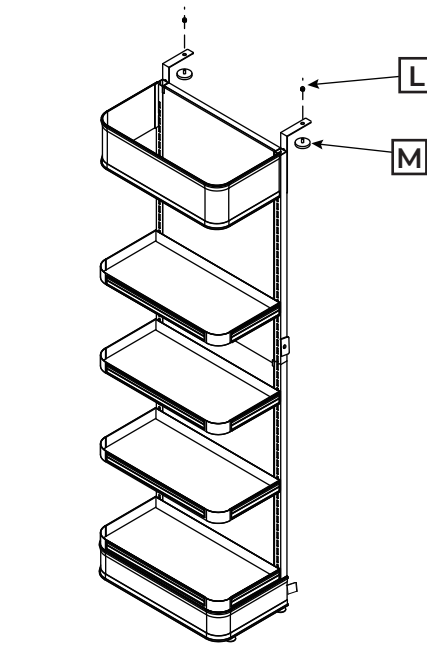

9 Place the assembled display against either side of the cooler and adjust the position of the (F) Brackets so that the (M) Magnets adhere to the top of the cooler. Adjust the position of the (N) Z Brackets so they match the bottom of the cooler. Adjust Magnets on (O) Magnet Brackets so that Magnets adhere to the side of the cooler.

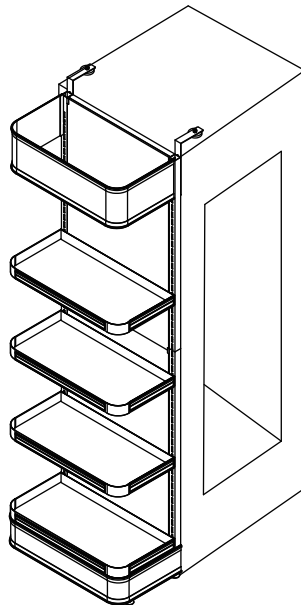
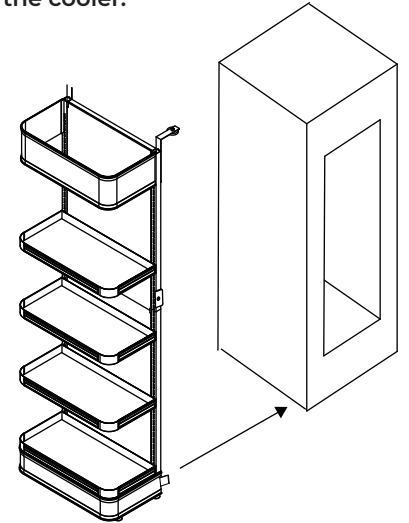

OR

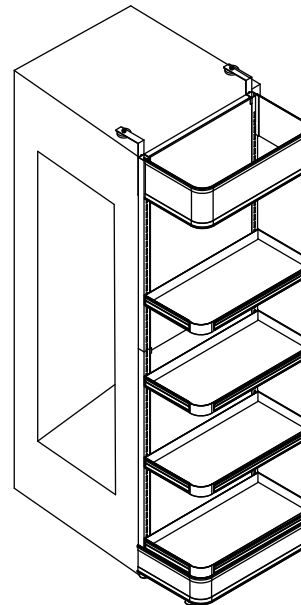

MISSING PARTS / DAMAGE CLAIM INSTRUCTIONS

1. **DO NOT** discard the box or original packaging.
In the case of damaged goods caused by shipping, photo evidence will be required.
2. Take photos of the box & markings.
A photo of the markings (text) on the side of the box is required for all cases in which a replacement part is needed. This helps to identify the item number and ensures the correct parts are pulled.
3. Take photos of damage (if applicable).
A photo of the damaged part(s) is always required to file a claim and expediently process the replacement part. Please make sure you keep the box even if it is damaged.
4. Send an email with the images requested.
Email a description of the claim along with the images required above at displaybuilds.com/contact or directly to help@displaybuilds.com. Call our toll-free number 1-866-308-8368 for further assistance.