







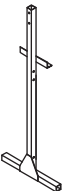

Herradura Metal Display - Assembly Instructions

JOB 19182

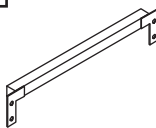
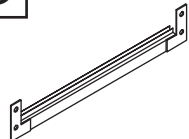

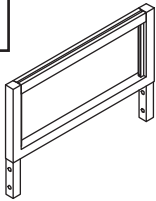
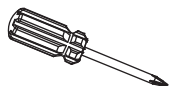
Scan the QR code or visit the web address directly to view the assembly video: displaybuilds.com/instructions_19182

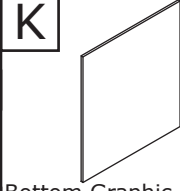
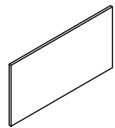
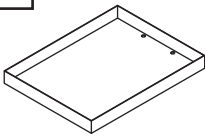

A  Left Bottom Side 1	B  Right Bottom Side 1	C  Top Bar 1	D  Bottom Bar 1	E  Right Top Side 1	F  Left Top Side 1
G  Header Frame 1	H  Screwdriver 1	I  M6 x 12 Screw 28	K  Bottom Graphic (not included) 1	L  Header Graphic (not included) 1	M  Acrylic Shelf 3
J  Feet 4					

1 Screw in x2 (J) Feet to (A) Left Bottom Side and x2 (J) Feet to (B) Right Bottom Side as shown below. Align (D) Bottom Bar between (A) Left Bottom Side and (B) Right Bottom Side. Slide the (K) Bottom Graphic into the opening in the (D) Bottom Bar as shown below. Then align (C) Top Bar between the sides to cover the top of the graphic.

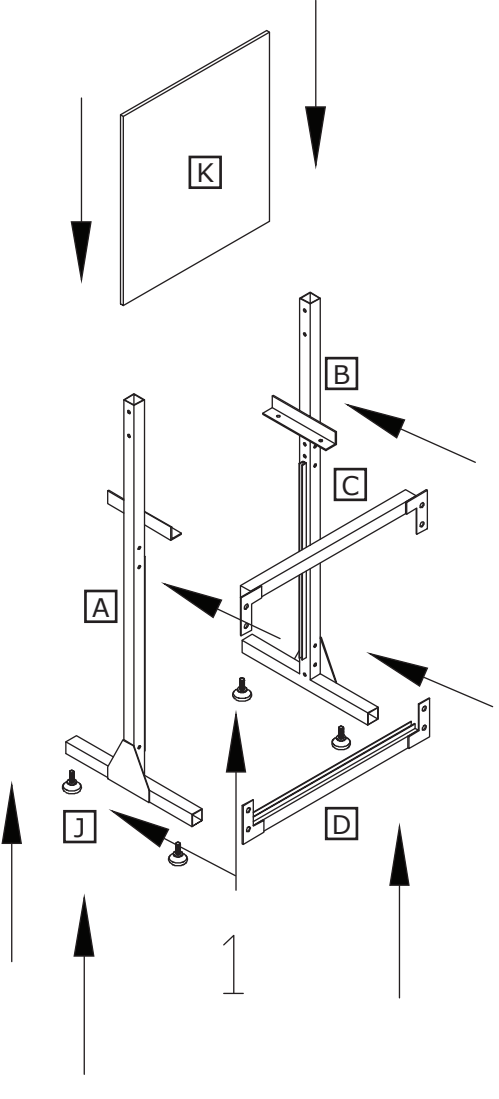

2 Thread x8 (I) M6 x 12 Screws to secure the bottom part, but don't tighten completely until step 3. Insert (E) Right Top Side and (F) Left Top Side into the bottom sides. Thread x4 (I) M6 x 12 Screws to secure the side pieces, but leave loose until step 3.

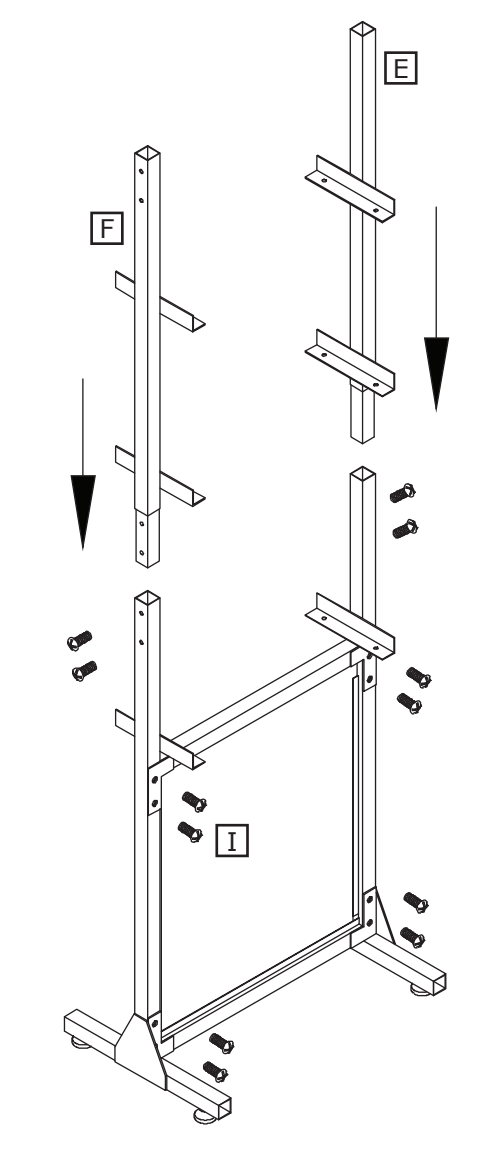

3 Attach x3 (M) Acrylic Shelves with x4 (I) M6 x 12 Screws per shelf (total of 12) as shown below. Once the shelves are in, tighten all the screws from step 2 with (H) Screwdriver.

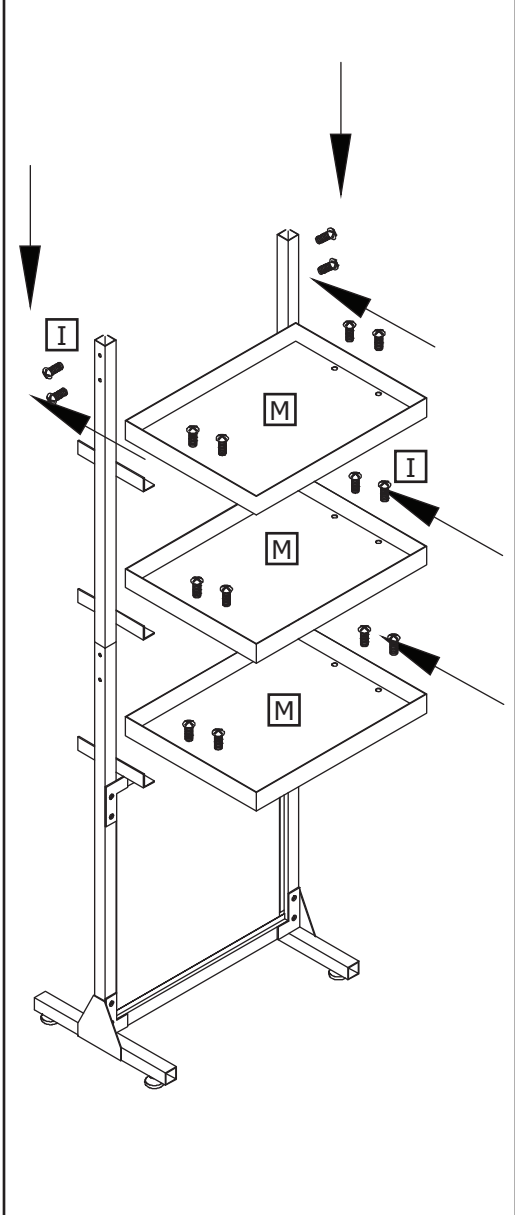

Herradura Metal Display - Assembly Instructions



Scan the QR code or visit the web address directly to view the assembly video: displaybuilds.com/instructions_19182



- 4** Insert (G) Header Frame into the top sides. Thread x4 (I) M6 x 12 Screws to secure the frame, and tighten with (H) Screwdriver. Slide (L) Header Graphic into the opening of (G) Header Frame.

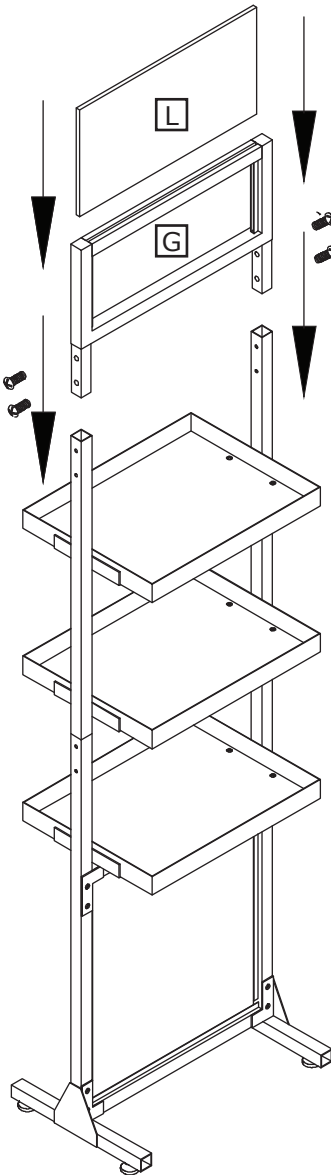

- 5** Assembly is completed.

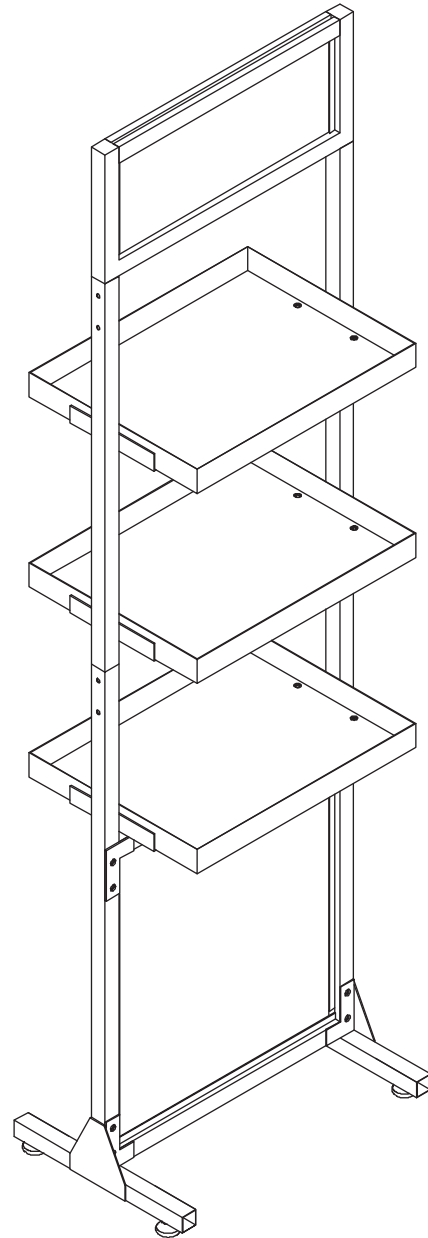

MISSING PARTS / DAMAGE CLAIM INSTRUCTIONS

- DO NOT** discard the box or original packaging.
In the case of damaged goods caused by shipping, photo evidence will be required.
- Take photos of the box & markings.
A photo of the markings (text) on the side of the box is required for all cases in which a replacement part is needed. This helps to identify the item number and ensures the correct parts are pulled.
- Take photos of damage (if applicable).
A photo of the damaged part(s) is always required to file a claim and expediently process the replacement part. Please make sure you keep the box even if it is damaged.
- Send an email with the images requested.
Email a description of the claim along with the images required above at displaybuilds.com/contact or directly to help@displaybuilds.com. Call our toll-free number 1-866-308-8368 for further assistance.