

KDP DG 20oz Rack (Large) - Assembly Instructions

JOB 19167

Scan the QR code or visit the web address directly to view the assembly video: displaybuilds.com/instructions_19167

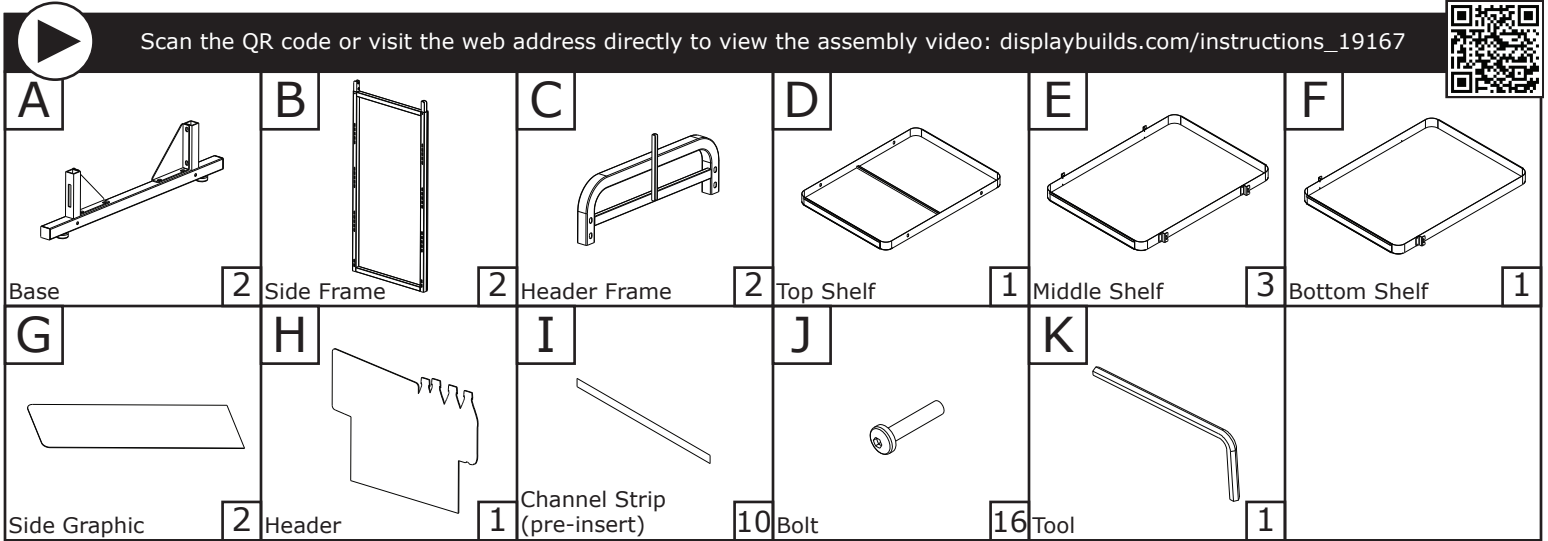

1 Slide one (B) Side Frame into x2 (A) Bases. Repeat with the other (B) Side Frame. Secure Bases and Side Frames with x8 (J) Bolts using (K) Tool.

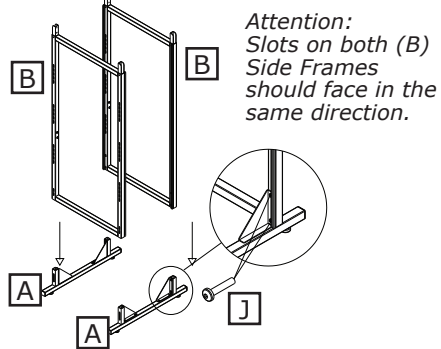

2 Slide x2 (C) Header Frames into (B) Side Frames. Attach (D) Top Shelf to (B) Side Frames. Secure Header Frames, Side Frames, and Top Shelf with x8 (J) Bolts using (K) Tool.

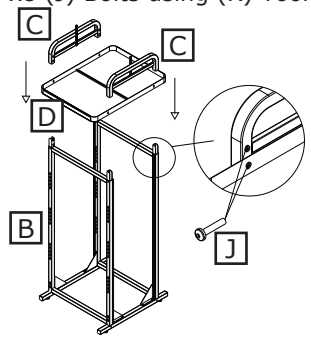

3 Hook (F) Bottom Shelf onto (B) Side Frames. Hook x3 (E) Middle Shelves onto (B) Side Frames at required positions.

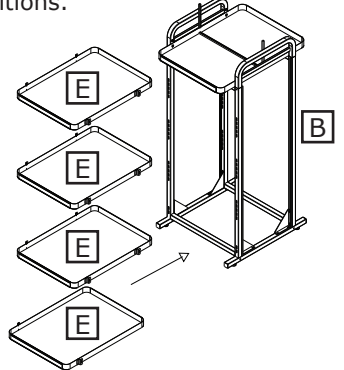

4 Slide each (G) Side Graphic into (B) Side Frames, or attach each (G) Side Graphic to the (B) Side Frames with the magnets on the back.

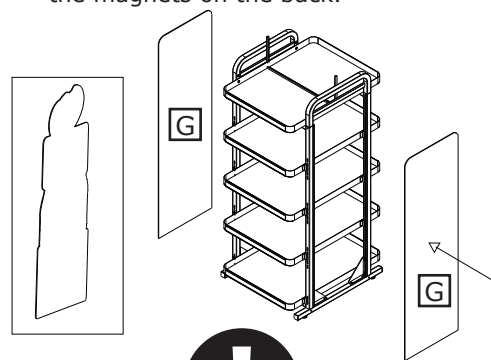

5 Insert (H) Header into top channels. Remove foils at both ends of x10 (I) Channel Strips.

Remove foils at both ends of Channel Strips.

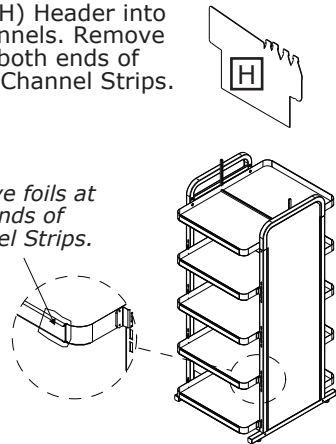

6 Assembly is completed.

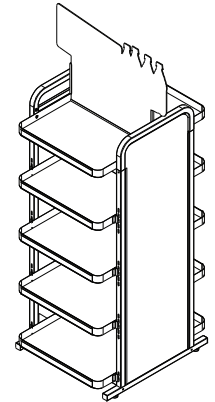

MISSING PARTS / DAMAGE CLAIM INSTRUCTIONS

- DO NOT** discard the box or original packaging.
In the case of damaged goods caused by shipping, photo evidence will be required.
- Take photos of the box & markings.
A photo of the markings (text) on the side of the box is required for all cases in which a replacement part is needed. This helps to identify the item number and ensures the correct parts are pulled.
- Take photos of damage (if applicable).
A photo of the damaged part(s) is always required to file a claim and expediently process the replacement part. Please make sure you keep the box even if it is damaged.
- Send an email with the images requested.
Email a description of the claim along with the images required above at displaybuilds.com/contact or directly to help@displaybuilds.com. Call our toll-free number 1-866-308-8368 for further assistance.