

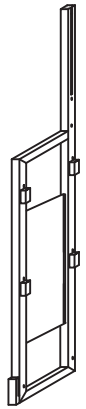

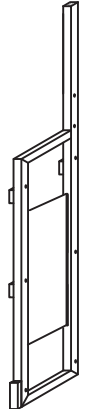

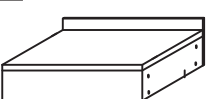



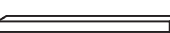

# Bottle Shelf Display / 'Diplomatico' - Assembly Instructions

|  |  |
|--|--|
| <p><b>A</b></p>  <p>Left Side Panel</p> <p>1</p>        | <p><b>B</b></p>  <p>Right Side Panel</p> <p>1</p> |
| <p><b>C</b></p>  <p>Base</p> <p>1</p>                    | <p><b>D</b></p>  <p>Shelf</p> <p>2</p>            |
| <p><b>E1</b></p>  <p>Middle Bar</p> <p>1</p>            | <p><b>F</b></p>  <p>Top Bar</p> <p>1</p>          |
| <p><b>E2</b></p>  <p>Bottom Bar</p> <p>1</p>            | <p><b>G</b></p>  <p>Header POS</p> <p>1</p>     |
| <p><b>I</b></p>  <p>Hex Flat Screw</p> <p>20</p>      | <p><b>K</b></p>  <p>Tool</p> <p>1</p>           |
| <p><b>J</b></p>  <p>Phillips Sharp Screw</p> <p>4</p> | <p><b>L</b></p>  <p>Screwdriver</p> <p>1</p>    |

▶ Scan the QR code or visit the web address directly to view the assembly video: [displaybuilds.com/instructions\\_19376](http://displaybuilds.com/instructions_19376)



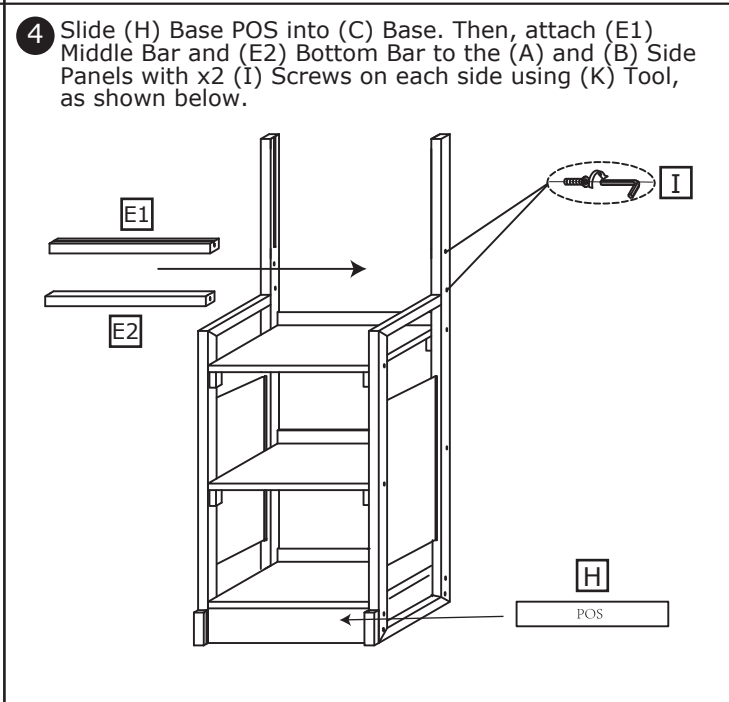
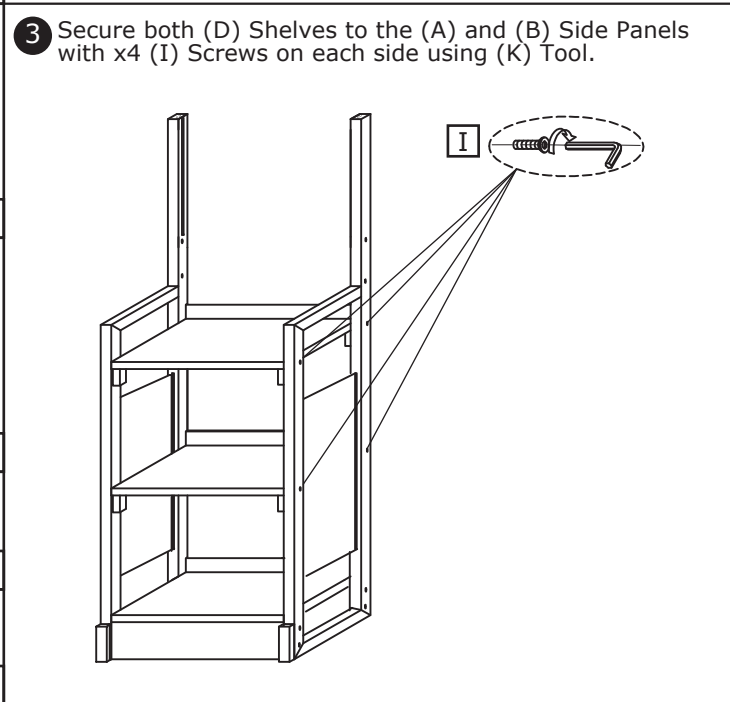
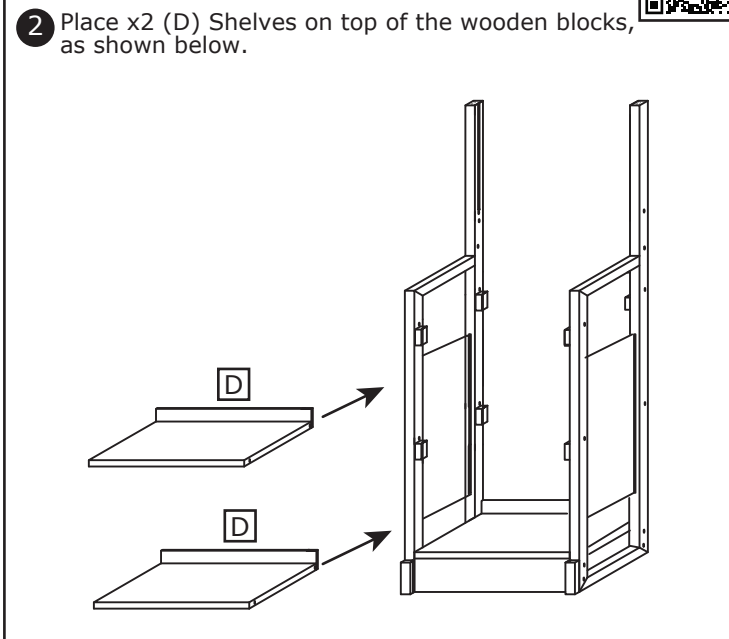
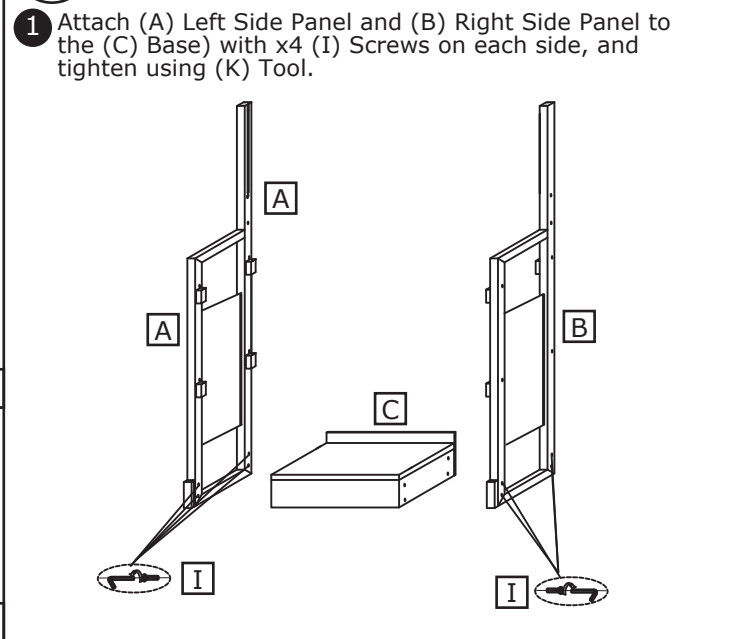

Scan the QR code or visit the web address directly to view the assembly video: [displaybuilds.com/instructions\\_19376](http://displaybuilds.com/instructions_19376)



- 5** Slide (G) Header POS into (E1) Middle Bar. Then, attach (F) Top Bar on top of the (A) and (B) Side Panels with x2 (J) Screws on each side using (L) Screwdriver, as shown below.

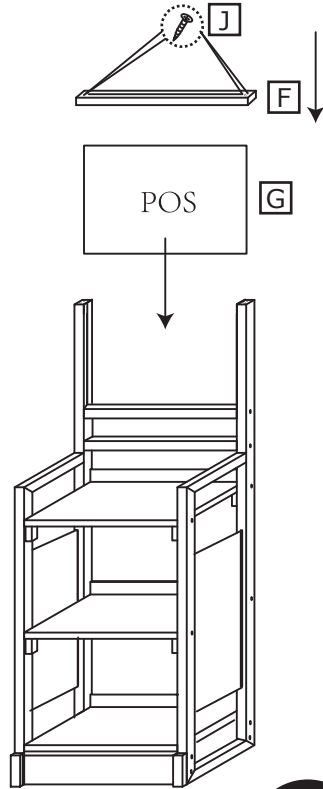

- 8** Assembly completed.

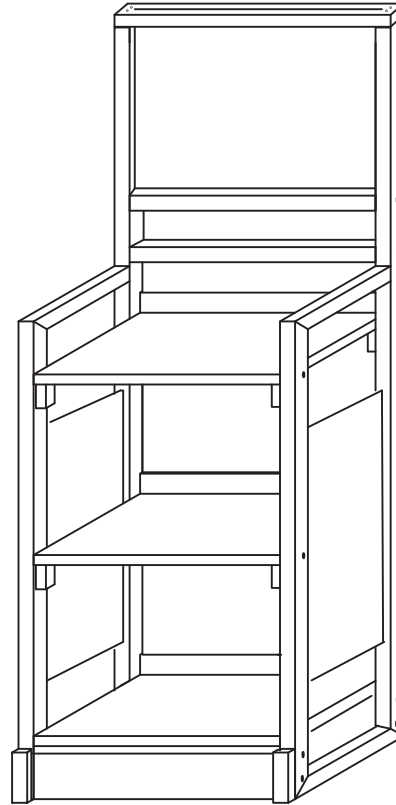

- 9** To replace/remove Side Panel Graphics, use (L) Screwdriver to remove a Screw on each side, take out old graphics and replace with the new, if needed. Then, use (L) Screwdriver to put the Screws back in to secure the graphics, if needed.

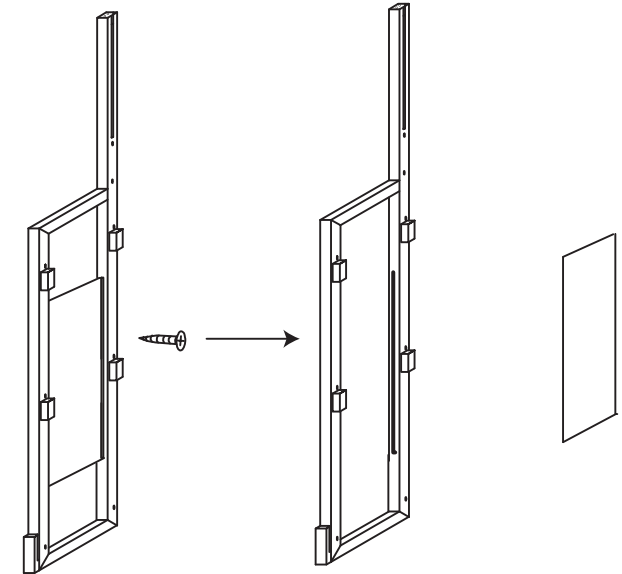

## MISSING PARTS / DAMAGE CLAIM INSTRUCTIONS

1. DO NOT discard the box or original packaging.  
In the case of damaged goods caused by shipping, photo evidence will be required.
2. Take photos of the box & markings.  
A photo of the markings (text) on the side of the box is required for all cases in which a replacement part is needed. This helps to identify the item number and ensures the correct parts are pulled.
3. Take photos of damage (if applicable).  
A photo of the damaged part(s) is always required to file a claim and expediently process the replacement part. Please make sure you keep the box even if it is damaged.
4. Send an email with the images requested.  
Email a description of the claim along with the images required above at [displaybuilds.com/contact](http://displaybuilds.com/contact) or directly to [help@displaybuilds.com](mailto:help@displaybuilds.com).  
Call our toll-free number 1-866-308-8368 for further assistance.